

A PASSION FOR PERFECTION

[www.idealvac.com](http://www.idealvac.com)  
**Ideal**  
vacuum products  
(505)872-0037

**PFEIFFER**  VACUUM



## SmartTest

**Helium Leak Detector – The clever and modular Solution.  
Simple Operation. Top Performance.**

## **Helium Leak Detector – The clever and modular Solution. Simple Operation. Top Performance.**

### **Helium leak detection the easy way**

With its modular design and its new wireless remote control RC 500 WL, the SmartTest offers the perfect solution for vacuum leak detection.

Fast, reliable results, lowest detectable leak rates and short recovery time are what characterize the SmartTest and make it such a powerful and dependable product.

Further advantages for you include minimum service requirements, robust engineering and the utmost in dependability. A broad selection of interfaces affords simple system integration.

### **More convenience**

Thanks to the RC 500 WL you can control your process much more convenient. All functions of your leak detector can be remote operated up to 100 m. The measured values can easily be displayed on the 3.5" touchscreen and stored in an internal memory of the remote control.

Take advantage of the opportunity for an on-site product presentation at your facility. It's the best way to experience the SmartTest in action!



Accelerator



Solar cell technology



Refrigeration, air conditioning



### Simple operation

With its eight basic setting keys, you only have to program your SmartTest once. The zero key enables you to display even the smallest leaks.

The START/STOP function offers a simple and secure way to start and stop the measurement.



*ZERO KEY for suppressing the background signal*

*One-key operation START/STOP*

**Helium Leak Detector – The clever and modular Solution.  
Simple Operation. Top Performance.**

**Modular concept**

A variety of configurations offers the optimum solution for your application:

- with a rotary vane pump, for general leak detection
- with a dry compressing pump, for absolutely oil-free leak detection
- without a backing pump, for use in leak detection systems



**Bypass option**

The bypass option affords fast leak detection when testing large items.

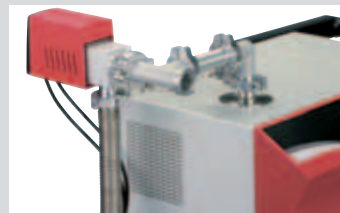

Bypass option

Overview of series

Leak detector	Pumping speed backing pump [m³/h]		Pump down time until ready for operation [s]		
	Rotary vane pump	Dry compressing pump	Volume of the item to be tested		
			0.5 l	10 l	100 l
HLT 550* without backing pump	dependant on external backing pump				
HLT 560 with integrated rotary vane pump	5	–	1	45	590
HLT 570 with integrated diaphragm pump	–	2	1	125	1,300
HLT 565 with external rotary vane pump UNO 30 M and cart	30	–	1	16	160
HLT 572 with external dry compressing pump XtraDry™ and cart	–	7.5	1	35	410
HLT 575 with external dry compressing pump and cart	–	28	1	16	160

\* A backing pump is required for operation



The SmartTest HLT 572 with cart and the XtraDry™ dry pump for testing valves in air conditioning

## Helium Leak Detector – The clever and modular Solution. Simple Operation. Top Performance.

### Integral leak detection for determining the total leak rate

The item to be tested is placed in a test chamber, filled with helium to test pressure and tested for leaks. The helium, which can egress through even the smallest leaks, reaches the SmartTest unit, enabling leak detection rates of down to  $10^{-12}$  mbar l/s\*.

The integral leak detection is suitable for either sniffer leak detection or vacuum leak detection.

- Measurement of the total leak rate in smaller test items
- Clear GO/NO-GO indication
- Highest objective measurement accuracy
- Short cycle time

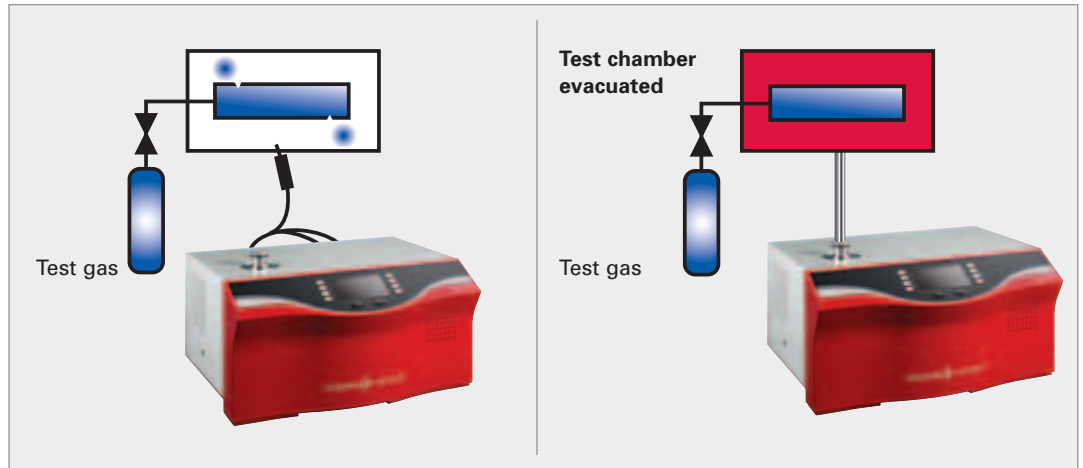

#### Sniffer leak detection

- Overpressure-resistant test item
- Use of a sniffer probe
- Detection limit  $< 5 \cdot 10^{-8}$  mbar l/s

#### Vacuum leak detection

- Vacuum-tight test item
- Test item filled with helium
- Detection limit  $< 5 \cdot 10^{-12}$  mbar l/s

\* 1 mbar l/s = 0.1 Pa m<sup>3</sup>/s = 0.987 sccs

### Helium leak detection – The right test method for every application

Selection of the appropriate quality assurance method for products and production processes is based upon the nature and size of the item to be tested.

In helium leak detection, a distinction is made between two different test methods – integral and local leak detection.

**Local leak detection for identifying individual leaks**

The local leak detection, too, is also suitable for either sniffer leak detection or vacuum leak detection. Sniffer leak detection is performed by filling the item to be tested with helium and testing with a sniffer probe.

In vacuum leak detection, the item to be tested is first evacuated and then sprayed with helium. Local leak detection identifies leaks of down to  $10^{-12}$  mbar l/s\* and provides

precise information about the size and location of any leaks.

- Precise localization of the leak site in large test items
- Indication of the exact magnitude of the leak
- High measurement accuracy
- Repetitive production defects can be easily identified

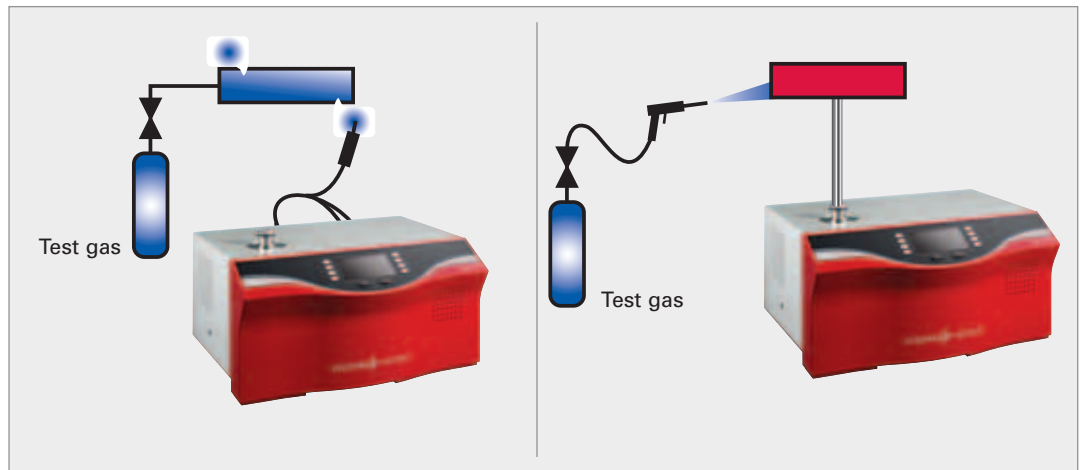

Sniffer leak detection	Vacuum leak detection
■ Overpressure-resistant test item	■ Vacuum-tight test item
■ Use of a sniffer probe	■ Spraying with helium
■ Detection limit $< 5 \cdot 10^{-9}$ mbar l/s	■ Detection limit $< 5 \cdot 10^{-12}$ mbar l/s

\* 1 mbar l/s = 0.1 Pa m<sup>3</sup>/s = 0.987 sccs

**Helium – The ideal test gas**

Only a minute percentage of this gas is contained in the atmosphere, enabling even the smallest leak rates to be identified. Because of their very low atomic mass, helium atoms move through the air at higher speed. This ensures very fast measurements.

Further advantages at a glance:

- Utmost sensitivity in identifying even the smallest leaks
- Quantification of the leaks
- Outstanding reproducibility of the measurement
- Helium test gas is non-toxic and non-flammable
- Short measurement times



**Helium Leak Detector – The clever and modular Solution.  
Simple Operation. Top Performance.**

**Remote control  
RC 500/RC 500 WL**

- The RC 500 WL allows remote operation up to 100 m
- Easy single-handed operation thanks to 3.5" touchscreen display
- Measured values can be stored in RC 500 or on USB stick
- Compatible to previous SmartTest generations
- More than 8 hours of battery life
- Operation of up to 5 leak detectors at once



**Display**

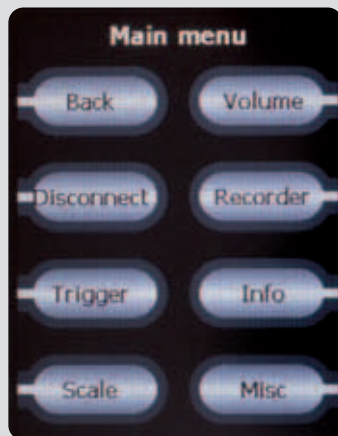

Main menu

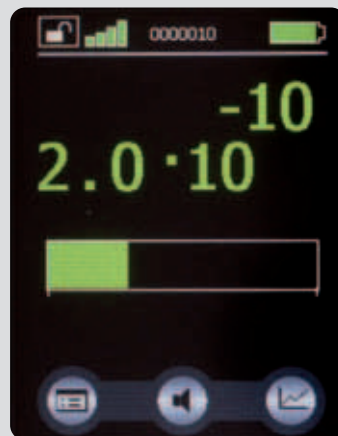

Measured values

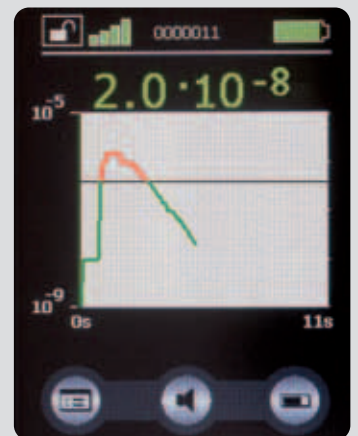

Chart mode



## Dimensions

### SmartTest

HLT 550  
HLT 560  
HLT 570

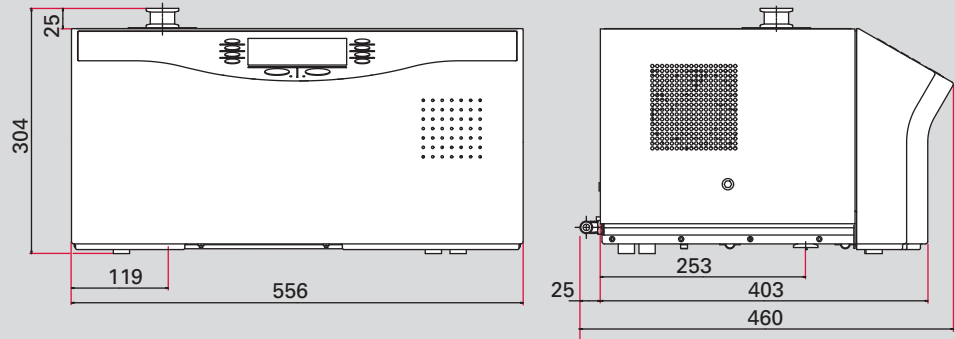

### SmartTest with cart

HLT 565  
HLT 572  
HLT 575

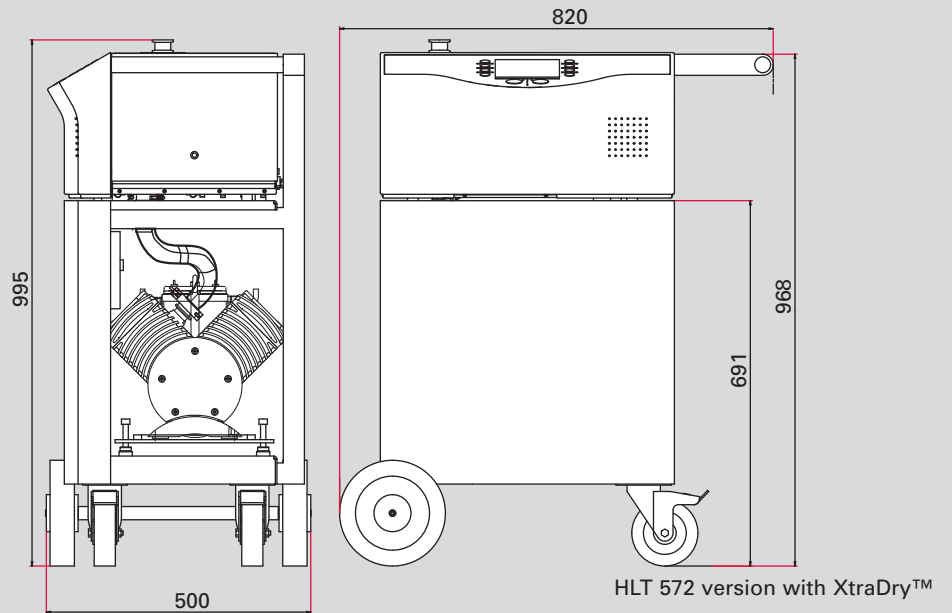

Dimensions in mm

## Connections and interfaces for accessories

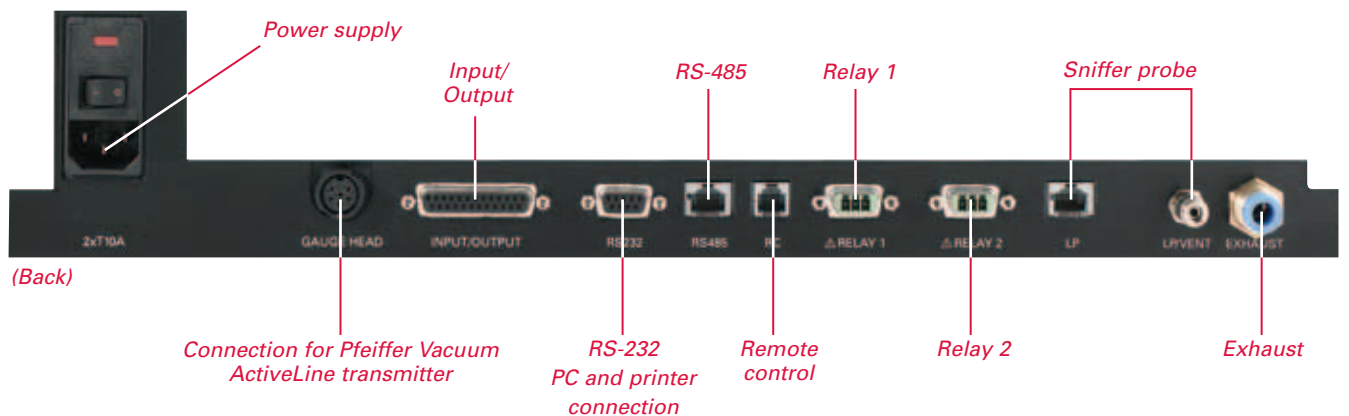

## Helium Leak Detector – The clever and modular Solution. Simple Operation. Top Performance.

### General technical data

SmartTest	HLT 550 – 575
Smallest detectable leak rate for He (Vacuum leak detection)	< 5·10 <sup>-12</sup> mbar l/s
Smallest detectable leak rate for He (Sniffer leak detection)	< 5·10 <sup>-8</sup> mbar l/s
Test method	Vacuum and sniffing leak detection
Detectable gases	<sup>4</sup> He, <sup>3</sup> He, H <sub>2</sub>
Internal He-Test leak	10 <sup>-7</sup> mbar l/s
Leak rate display	10 <sup>-12</sup> – 1 mbar l/s
Cold start to ready	3 min
Response time	0.5 s
Pumping speed: for He	2,5 l/s
Flange (in)	DN 25 ISO-KF
Inlet pressure max.	25 mbar
Ambient temperature	+10 bis +35 °C
Interface	RS-232-C, RS-485
Analog – Output	Leak rate signal 2 x 0–10 V, lin/log
Digital – Output	Ready to start, Ready to measure, Leak, Error, Bypass valve, Calibration acknowledge
Relay – Output	2 x 230 VAC/3 A

### Technical data

	HLT 550*	HLT 560	HLT 570	HLT 565 with cart	HLT 572 with cart	HLT 575 with cart
Backing pump	without	Rotary vane pump (integrated) 5 m <sup>3</sup> /h	Diaphragm pump (integrated) 2 m <sup>3</sup> /h	Rotary vane pump UNO 30 M (external) 30 m <sup>3</sup> /h	Dry pump XtraDry™ (external) 7.5 m <sup>3</sup> /h	Dry pump (external) 28 m <sup>3</sup> /h
Power consumption	150 VA	400 VA	300 VA	900 VA/50 Hz, 1,050 VA/60 Hz	700 VA	900 VA
Weight	34 kg	44 kg	44 kg	133 kg	119 kg	140 kg

\* A backing pump is required for operation

### Order numbers – SmartTest

	HLT 550*	HLT 560	HLT 570	HLT 565 with cart	HLT 572 with cart	HLT 575 with cart
230 V, 50 Hz	PT L02 120	PT L02 100	PT L02 110	PT L02 150	PT L02 160	PT L02 165
120 V, 60 Hz	PT L02 120	PT L02 101	PT L02 111	PT L02 151	PT L02 161	PT L02 166
100 V, 50/60 Hz	PT L02 120	PT L02 102	PT L02 112	PT L02 151	PT L02 162	PT L02 166

\* A backing pump is required for operation

## Order numbers – Accessories

Accessories	Order numbers
<b>Remote control</b>	
Remote control RC 500 WL, wireless <sup>1)</sup>	PT 445 420-T
Remote control RC 500 <sup>2)</sup>	PT 445 421-T
Connection cable for remote control RC 500, 4 m	PT 445 401
Extension cable, 8 m	PT 445 402
<b>External test leak</b>	
CT 408, He-Test leak, leak rate approx. $10^{-5}$ mbar l/s, DN 10 ISO-KF	B8 116 557
CT 446, He-Test leak, leak rate adjustable $10^{-6} - 10^{-4}$ mbar l/s, DN 10 ISO-KF	B8 115 580
<b>Bypass option</b>	
with mains cable with Euro-style safety plug	PT 445 410-T
with mains cable with US plug	PT 445 412-T
<b>Cart with electrical connection</b>	
100–120 V AC	PT 445 416
230 V AC	PT 445 415
<b>Sniffer probe</b>	
LP 503, 3 m	BG 449 207-T
LP 505, 5 m	BG 449 208-T
LP 510, 10 m	BG 449 209-T
<b>Calibrated sniffer test leak</b>	
CL 004, He, leak rate approx. $10^{-4}$ mbar l/s	BG 447 704-T
CL 004, He, leak rate approx. $10^{-5}$ mbar l/s	BG 447 705-T
CL 004, He, leak rate approx. $10^{-6}$ mbar l/s	BG 447 706-T
CL 002 A, Mixture He : H <sub>2</sub> = 95 % : 5 %, leak rate H <sub>2</sub> approx. $10^{-6}$ mbar l/s	BG 449 025A
<b>Software</b>	
Software for SmartTest Helium Leak Detector	PT 882 610-T
USB converter to RS-485 interface	PM 061 207-T
Interface cable RJ 45 on M 12 for using USB/RS-485 Converter	PM 051 726-T
<b>Other accessories</b>	
Centering ring with poral filter, FPM/stainless steel, DN 25 ISO-KF	PF 117 225-T
Connection flange (input) DN 25 ISO-KF to connect an external, additional backing pump	PT 445 417
Helium pistol	BG 512 125-T
Signal-Tower	B 468 1891 KC
Transport case for SmartTest, dimensions: 730 x 570 x 500 mm, weight: 18 kg	PT 445 403
Scratch guard	PT 445 404

<sup>1)</sup> Scope of delivery: charger, wireless transmitter

<sup>2)</sup> Scope of delivery: spiral cable 4 m

**Leading. Dependable.  
Customer Friendly.**

Pfeiffer Vacuum stands for innovative and custom vacuum solutions worldwide, for German engineering art, competent advice and reliable service.

Ever since the invention of the turbopump, we've been setting standards in our industry and this claim to leadership will continue to drive us in the future.

**Are you looking for a  
perfect vacuum solution?  
Please contact us:**

**Germany (Headquarters)**  
Pfeiffer Vacuum GmbH  
Phone: +49 (0) 6441 802-0  
info@pfeiffer-vacuum.de

**Austria**  
Pfeiffer Vacuum Austria GmbH  
Phone: +43 1 894 17 04  
office@pfeiffer-vacuum.at

**Benelux**  
Pfeiffer Vacuum GmbH  
Sales & Service Benelux  
Phone: +800-pfeiffer  
benelux@pfeiffer-vacuum.de

**China**  
Pfeiffer Vacuum  
(Shanghai) Co., Ltd.  
Phone: +86 21 3393 3940  
info@pfeiffer-vacuum.cn

**France**  
Pfeiffer Vacuum France SAS  
Phone: +33 169 30 92 82  
info@pfeiffer-vacuum.fr

**India**  
Pfeiffer Vacuum India Ltd.  
Phone: +91 40 2775 0014  
pfeiffer@vsnl.net

**Italy**  
Pfeiffer Vacuum Italia S.p.A.  
Phone: +39 02 93 99 05 1  
contact@pfeiffer-vacuum.it

**Korea**  
Pfeiffer Vacuum Korea Ltd.  
Phone: +82 31 266 0741  
sales@pfeiffer-vacuum.co.kr

**Russia**  
OOO Pfeiffer Vacuum Rus  
Phone: +7 495 411 7962  
office@pfeiffer-vacuum.ru

**Sweden**  
Pfeiffer Vacuum Scandinavia AB  
Phone: +46 8 590 748 10  
sales@pfeiffer-vacuum.se

**Switzerland**  
Pfeiffer Vacuum (Schweiz) AG  
Phone: +41 44 444 22 55  
info@pfeiffer-vacuum.ch

**United Kingdom**  
Pfeiffer Vacuum Ltd.  
Phone: +44 1908 500600  
sales@pfeiffer-vacuum.co.uk

**USA**  
Pfeiffer Vacuum Inc.  
Phone: +1 603 578 6500  
contact@pfeiffer-vacuum.com

[www.pfeiffer-vacuum.com](http://www.pfeiffer-vacuum.com)