



**Ideal**  
vacuum products  
(505) 872-0037

# AGILENT IDP-3 DRY SCROLL PUMP

Dry Technology. High Performance.

The Measure of Confidence



**Agilent Technologies**

# High Performance. Compact. Dry.

High performance in a compact package – the Agilent IDP Series Dry Scroll Pumps provide affordable oil-free vacuum with easy system and they are suitable for a wide variety of applications.

The IDP Series employs an innovative hermetic design in which the motor and bearings are outside the vacuum

space allowing full isolation of all pumped gases. In addition, the IDP dry pump technology is environmentally friendly, as it eliminates the need for oil disposal or the handling of contaminated oil in your laboratory.

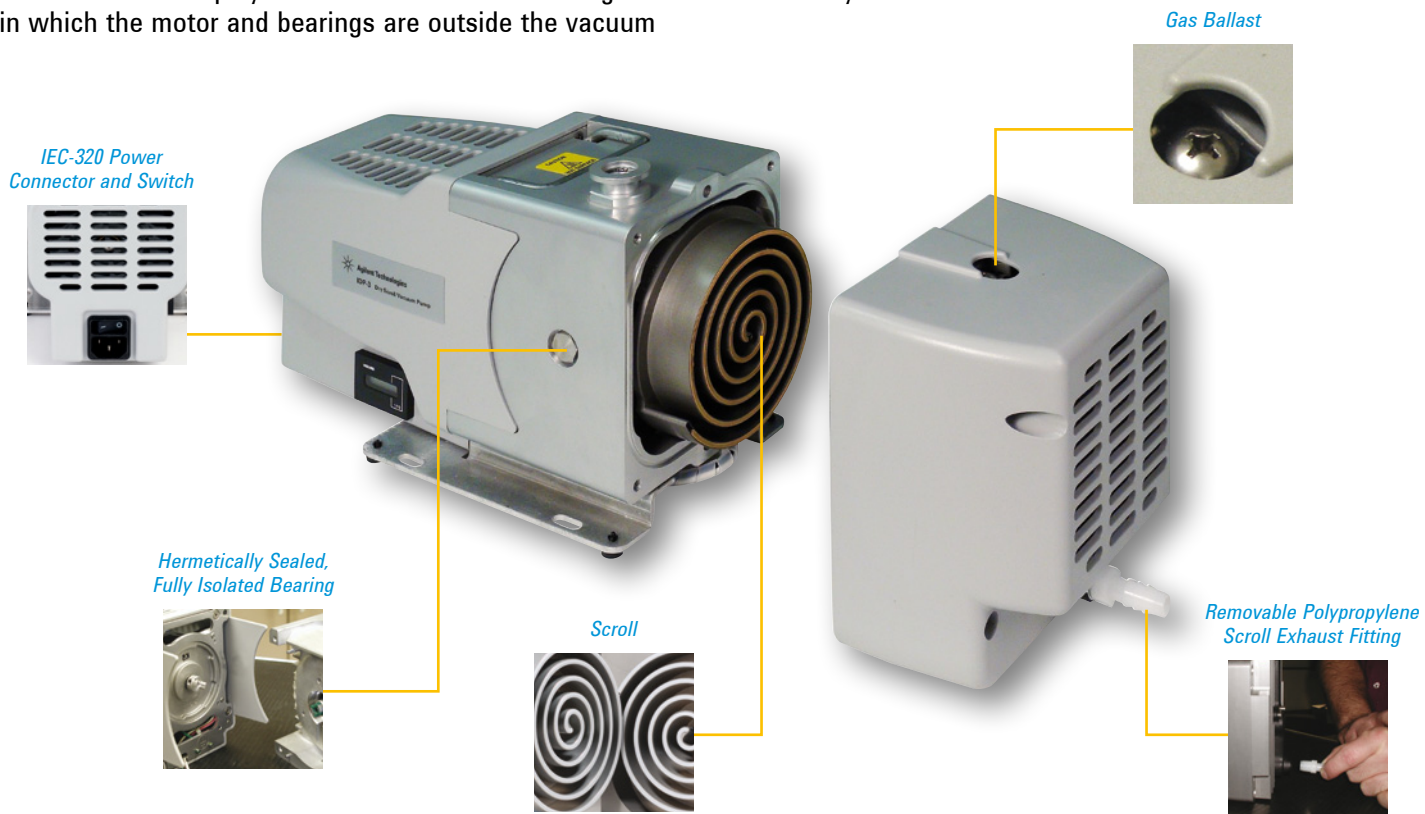

## Understanding Scroll Pump Technology



Gas enters scroll set



Gas is displaced and...



...compressed toward center hub



Gas exhausted at center hub

IDP Pumps create vacuum using a simple dual scroll mechanism in which one of the nested scrolls orbits about the other, creating moving zones of captured gas. Gas enters the scroll set at the perimeter and is displaced and compressed toward the center hub where it is exhausted.

The uncomplicated dual scroll design offers many benefits including lower noise and vibration levels, simple and infrequent maintenance requirements, plus the elimination of catastrophic failure modes.

## High Pumping Speed. Low Base Pressure.

Agilent IDP Series Scroll Pumps, with high pumping speed and very low base pressure, provide all the advantages of scroll pump technology in a clean, compact, lightweight, and cost-effective package.



- Pumping speed of 60 l/m 7 (3.6 m<sup>3</sup>/hr)
- Very low base pressure of less than 250 mTorr (0.3 mbar)
- Truly high-performance solution for demanding applications

### Why Choose IDP Series?

#### IDP Series vs. Rotary Vane Pumps

- Oil-free technology of IDP Pumps eliminate the possibility of oil contamination in the vacuum system or of oil spills or leaks into the work environment.
- Maintenance of the IDP Pumps require only a simple, infrequent tip seal change as compared to oil checks, changes, and disposal.
- The IDP Pumps do not depend on the presence of sufficient oil to prevent seizing.

#### IDP Series vs. Membrane Diaphragm Pumps

- IDP Pumps are compact at 358 x 181 x 140 mm (14 x 7 x 6 in.), yet provide base pressure of less than 250 mTorr, almost 4 times lower than equivalently sized membrane/diaphragm pump.
- In turbo pump applications, the pumps' lower base pressure reduce power consumption and bearing temperature and increase the reliability of the system.
- IDP Pumps avoid catastrophic failure mechanisms. A diaphragm pumped system may suffer sudden, rapid loss of pressure when a membrane ruptures.
- IDP Pumps produce lower noise and vibration levels than diaphragm pumps, creating a quiet, pleasant work environment, and much lower contribution to system noise and vibration.

# Features and Benefits



## Powerful – High Performance

IDP Dry Scroll Pumps deliver better vacuum performance than other pumps of similar size.

- High pumping speed provides rapid pumpdown and high gas throughput
- Very low base pressure ensures optimal turbo pump performance with increased system reliability

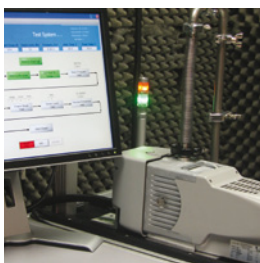

## Oil-free – Affordable Dry Vacuum

Convenient, low maintenance pumps provide affordable dry vacuum for research and industrial applications alike.

- IDP Pumps eliminate hydrocarbon contamination in the vacuum system
- No oil leaks into the work environment



## Innovative – Hermetic Design

IDP Pumps fully isolate the bearings and motor from the vacuum space and contain all pumped gases.

- Allows recovery of precious process gases
- Prevents leakage of toxic gases



## Economical – Low Cost of Ownership

Robust, efficient scroll pump technology has a long service interval resulting in very low cost of ownership.

- Maintenance time and costs of oil topping, replacement and disposal are eliminated
- Simple tip seal or module exchange requires less than 30 minutes



## System Friendly – Easy to Integrate

With a small footprint, low weight, and low power requirements, IDP Pumps are easy to accommodate in system design.

- IDP Pumps place little additional burden on system utilities and are suitable for use inside cabinet enclosures
- At only 21 pounds (9.5 kg), IDP Pumps are lighter than mechanical rotary vane and membrane pumps of similar pumping speed
- Low noise and vibration provide a quiet, pleasant work environment

# Applications



## Analytical Instrumentation

Monitoring, maintenance and environmental challenges of oil disposal make oil-sealed rotary vane pumps, at best, a nuisance in the laboratory environment. Without oil, high capacity IDP Pumps provide your instrument the required pumping speed and base pressure not available with other dry pump technologies.

- GC/MS
- Residual gas analyzers
- Load locks for mass spectrometers
- Electron microscopes
- Surface area analyzers
- EM Sample prep coaters



## Semiconductor Fabrication

IDP Series hermetic design ensures against gas leakage into the environment, essential for evacuation and cycle purging of gas transfer lines and gas panels in wafer fabs. The pumps maintain ultra-pure gases by reducing the number of purge/vent cycles, so that on a single pumpdown the pumps low base pressure eliminates 99.9% of the volume gas.

- Gas panels
- Gas delivery systems
- Double wall containment vessels



## High Energy Physics

Chamber evacuation and backing of turbo pumps on beam lines are just a couple of the applications that benefit from the clean, dry pump technology of the IDP Series. A compact, rugged, high performance design makes it a superior choice over membrane pumps, and the 55 dBA noise spec makes it virtually unnoticeable in the work environment.

- Accelerators
- Beam lines
- Synchrotrons



## Industrial processing

IDP pumps deliver clean vacuum critical for many precision components – optics, lasers, electron devices – with a hermetically sealed design with all bearings outside the vacuum space. With low base pressure and high pumping speed, the IDP Series is the superior choice compared to membrane pumps.

- Laser evacuation
- Cryogenic dewars
- Glove boxes
- Gas recovery and recirculation
- Cryopump roughing
- Tube processing
- Vacuum chucks



## General Research & Development

A cost effective solution for clean vacuum when fast pumpdown times are desired, the IDP Series outperforms other dry technologies with higher retained pumping speed both at high pressure and at base vacuum.

- Experimental chambers
- Sample prep systems
- Surface analysis systems
- Backing turbo pump on beam lines

# Agilent IDP-3 Dry Scroll Pump



## Pumping Speed

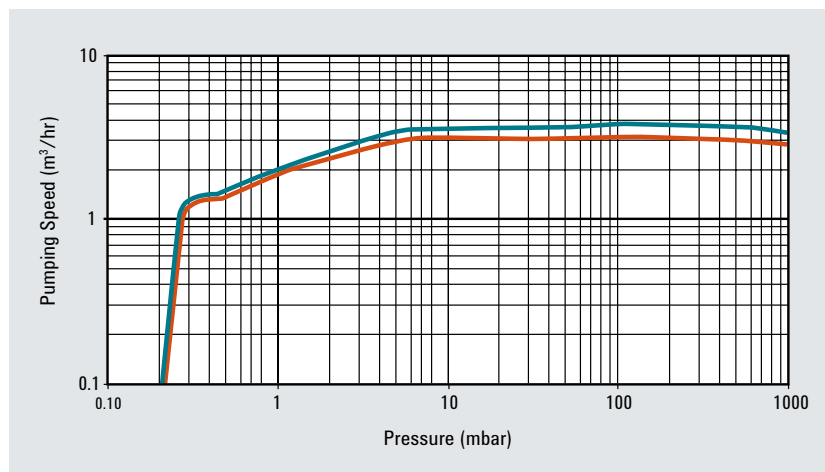

## Technical Specifications

Peak pumping speed	60 Hz:	60 l/m, 3.6 m <sup>3</sup> /hr, 2.1 cfm
	50 Hz:	50 l/m, 3.0 m <sup>3</sup> /hr, 1.8 cfm
Ultimate pressure		2.5 x 10 <sup>-1</sup> torr (3.3 x 10 <sup>-1</sup> mbar, 33 Pa)
Maximum inlet pressure		1 atmosphere (1.0 bar, 101 kPa)
Maximum outlet pressure		1.4 atmospheres (1.4 bar, 142 kPa)
Inlet connection		NW16 KF flange
Exhaust connection		Female 1/4 in. NPT (10 mm hose barb provided)
Gas ballast connection		Female 1/8 in. NPT
Ambient operating temperature		5 to 40°C (41 to 108°F)
Storage temperature		-20 to 60 °C (-4 to 140°F)
Motor rating		0.16 horsepower (0.12 kW)
Supply power		1Ø - 100 VAC, 50-60 Hz : 115 VAC, 60 Hz : 220-240 VAC, 50-60 Hz
Motor thermal protection		Automatic
Rotation speed	60 Hz:	3200 RPM
	50 Hz:	2600 RPM
Cooling		Air-cooled
Weight		9.5 kg (21 lbs); Shipping-10.5 kg (23 lbs)
Restrictions		No corrosive, explosive, or particulate-forming gases
Leak rate		<1 x 10 <sup>-6</sup> std-cc/sec helium
Noise level (per ISO 11201)		55 dB(A)
Vibration level at inlet (per ISO 10816-1)		1.5 mm/second
Compliance		Conforms with CE, CSA, CSA/CUS, Semi S2-703, and RoHS

## Ordering Information

IDP-3 Dry Vacuum Pumps	Standard	with Isolation Valve	Tip Seal Kit	Replacement Module
IDP-3, 1Ø, 220V, 50/60Hz	IDP3A01	IDP3A21	IDP3TS	IDP3
IDP-3, 1Ø, 115V, 50/60Hz	IDP3B01	IDP3B21	IDP3TS	IDP3
IDP-3, 1Ø, 100V, 50/60Hz	IDP3C01	IDP3C21	IDP3TS	IDP3
IDP-3, 24 VDC	IDP3D01	IDP3D21	IDP3TS	IDP3

### Power Cord Selection

Europe, 10A/220-230V, 2.5 Meter	656494220
Denmark, 10A/220-230V, 2.5 Meter	656494225
Switzerland, 10A/230V, 2.5 Meter	656494235
UK/Ireland, 13A/230V, 2.5 Meter	656494250
India, 10A/220-250V, 2.5 Meter	656494245
Israel, 10A/230V, 2.5 Meter	656494230
Japan, 12A/100V, 2.3 Meter	656494240
North America, 15A/125V, 2.0 Meter	656458203
North America, 10A/230V, 2.5 Meter	656494255

## Outline Drawing IDP-3 shown with IEC power connector

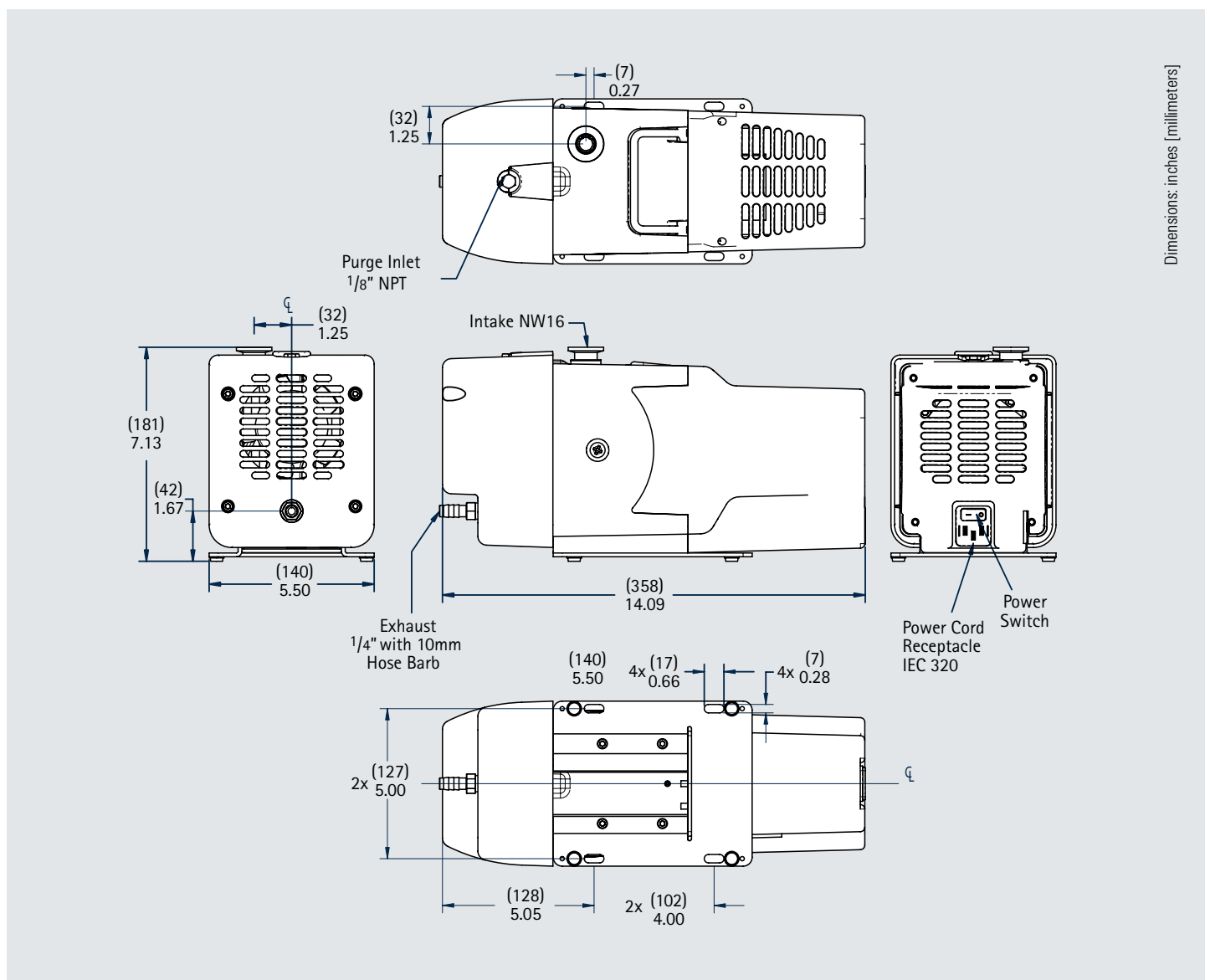

# Agilent IDP-3

## Agilent Technologies

### United States

Agilent Technologies  
121 Hartwell Avenue,  
Lexington MA 02421, USA  
Tel: +1 781 861 7200  
Fax: +1 781 860 5437  
Toll free: +1 800 882 7426  
vpl-customerservice@agilent.com

### China

#### Beijing Office

Agilent Technologies (China) Co. Ltd  
No.3, Wang Jing Bei Lu, Chao Yang District,  
Beijing, 100102, China  
Tel: +86 (0)10 64397888  
Fax: +86 (0)10 64391318  
Toll free: 800 820 3278  
vacuum.cnmarketing@agilent.com  
vpc-customerservice@agilent.com

#### Shanghai Office

Agilent Technologies  
2F, Building 4, No.690 Bibo Road,  
Zhangjiang Hi-Tech Park, Pudong District,  
Shanghai, 201203, China  
Tel: +86 (0)21 38507688  
Fax: +86 (0)21 50278465  
Toll free: 800 820 3278

#### Guangzhou Office

Agilent Technologies  
Unit 08, 66/F, Citic Plaza,  
233 Tian He Bei Rd  
Guangzhou, 510613, China  
Tel: +86 (0)20 38113988  
Fax: +86 (0)20 86695861  
Toll free: 800 820 3278

### Shenzhen Office

Agilent Technologies  
3/F Dutyfree Business Bldg.,  
No.6, 1st Fu Hua Road, Futian CBD,  
Shenzhen, 518048  
Tel: +86 (0)755 83079588  
Fax: +86 (0)755 82763181  
Toll free: 800 820 3278

### Brazil

Agilent Technologies Brasil  
Avenida Marcos Pentead de Ulhoa  
Rodrigues, 939 – 6º andar  
Castelo Branco Office Park,  
Torre Jacarandá - Tamboré  
Barueri, Sao Paulo CEP: 06460-040  
Toll free: 0800-728-1405

### Benelux

Agilent Technologies Netherlands BV  
Groenelaan 5, 1186 AA Amstelveen  
The Netherlands  
Tel: +31 20 547 2000  
Fax: +31 20 547 2093

### France

Agilent Technologies  
Parc Technopolis - Z.A. de Courtaboeuf  
3, avenue du Canada - CS 90263  
91978 Les Ulis cedex, France  
Tel: +33 (0) 1 64 53 61 15  
Fax: +33 (0) 1 64 53 50 01  
vpf.sales@agilent.com

### Germany and Austria

Agilent Technologies  
Sales & Services GmbH & Co. KG  
Lyoner Str. 20  
60 528 Frankfurt am Main, Germany  
Tel: +49 69 6773 43 2230  
Fax: +49 69 6773 43 2250

### India

Agilent Technologies India Pvt. Ltd.  
G01. Prime corporate Park, 230/231,  
Sahar Rd., Opp. Blue Dart Centre,  
Andheri (East), Mumbai, 400 099 India  
Tel: +91 22 30648287/8200  
Fax: +91 22 30648250  
Toll free: 1800 113037

### Italy

Agilent Technologies Italia SpA  
via F.lli Varian 54  
10040 Leini, (Torino), Italy  
Tel: +39 011 9979 111  
Fax: +39 011 9979 350  
Toll free: 00 800 234 234 00  
vpt-customerservice@agilent.com

### Japan

Agilent Technologies Japan, Ltd.  
8th Floor Sumitomo Shibaura Building  
4-16-36 Shibaura Minato-ku  
Tokyo 108-0023, Japan  
Tel: +81 3 5232 1253  
Fax: +81 3 5232 1710  
Toll free: 0120 655 040  
vpj-customerservice@agilent.com

### Korea

Agilent Technologies Korea Ltd.  
Shinsa 2nd Bldg. 1F, 966-5 Daechei-dong  
Kangnam-gu, Seoul, Korea 135-280  
Tel: +82 (0)2 2194 9449  
Fax: +82 (0)2 3452 3947  
Toll free: 080 222 2452  
vpk-customerservice@agilent.com

### Mexico

Agilent Technologies  
Concepcion Beistegui No 109  
Col Del Valle, C.P. 03100, Mexico, D.F.  
Tel: +52 5 523 9465  
Fax: +52 5 523 9472

### Singapore

Agilent Technologies Singapore Pte Ltd.  
No.1 Yishun Avenue 7, Singapore 768923  
Tel: +65 6215 8045  
Fax: +65 6754 0574  
Toll free: 1 800 2762622  
vps-customerservice@agilent.com

### Southeast Asia

Agilent Technologies Sales Sdn Bhd  
Unit 201, Level 2 uptown 2,  
2 Jalan SS21/37, Damansara Uptown  
47400 Petaling Jaya, Selangor, Malaysia  
Tel: +60 3 7712 6106  
Fax: +60 3 6733 8121  
Toll free: 1 800 880 805  
vps-customerservice@agilent.com

### Taiwan

Agilent Technologies Taiwan Limited  
20 Kao-Shuang Road Ping-Chen City  
Tao-Yuan Hsien,  
32450 Taiwan, R.O.C.  
Tel: +886 3 4959004  
Toll free: 0800 018 768  
vpw-customerservice@agilent.com

### UK and Ireland

Agilent Technologies UK Ltd.  
6 Mead Road, Oxford Industrial Park  
Yarnton, Oxford OX5 1QU, UK  
Tel: +44 (0) 1865 291570  
Fax: +44 (0) 1865 291571



This information is subject to change without notice

© Agilent Technologies, Inc. 2014  
Published Jun 30, 2014  
VPD-0214EN

Scan the QR code  
with your smartphone  
for more information



Agilent Technologies