

Spray Dryer

Fine powder: 40 to 100µm with larger capacity

DL410

Evaporated water	Max. 3,000mL/h	Temp. control range	40 to 300°C	Sample flow	Variable up to 70ml/min.	Spray nozzle (selectable)	Two-way nozzle	Operation	Easy operation
------------------	----------------	---------------------	-------------	-------------	--------------------------	---------------------------	----------------	-----------	----------------

Spray drying of fine powder as small as 100µm with a high recovery rate.



This spray dryer can produce fine particles from 40 to 100µm which are considered to be extremely difficult to produce in laboratories. It is useful for preliminary tests for pilot plant or expensive samples, micro capture spray drying research, substitute for general laboratory drying method etc.

The DL410 is a larger capacity spray dryer that also does not require the liquid sample or solution to undergo any pre or post-processes such as filtration, separation, or pulverization. The use of organic solvents is fully supported with the attachment of our GAS410 organic solvent recovery unit. Small, expensive and/or heat sensitive samples can be dried quickly and efficiently with this easy to operate system.

- Processes samples as small as 0.5 g of solid matter
- Safe for heat-sensitive samples, such as food or medical products
- No risk of contamination
- Digital display of inlet/outlet temperature and drying air volume
- Detachable drying chamber, cyclone and product vessel
- Fast and easy clean up
- Universal power supply and multilingual touch screen controller

Easy operation and maintenance

- The hot air inlet and drying chamber cover automatically move up and down, and since the cyclone and product vessel can easily be removed, cleaning and maintenance after your experiment is easy
- Control functions are conveniently arranged on the control panel for various conditions
- The temperature recorder, air flow meter, pressure gauge and other measurements allow easy control of experiment conditions

Specifications

Model	DL410
Water evaporation rate	Max. approx. 3,000 ml/h
Temperature control range	40°C - 300°C at inlet
Temperature control accuracy	± 1°C at inlet
Dry air flow rate	Max. 1.2 m³/min
Air spray pressure control range	0 - 600 k Pa (0-6 kg/cm²)
Spraying system	Two-way nozzle (Dia. of orifice: 0.7mm) Nozzle No.3 standard supply
Spray/hot air contact system	Downward spray parallel flow system
Temperature controller	PID digital temperature controller
Temperature sensor	K thermocouple
Stainless pipe heater	2kW x 2 at 240V
Sample liquid feeding pump	Quantitative peristaltic pump, flow rate variable up to 70ml/min.
Solvent recovering capability (optional)	Organic solvent recovery unit GAS410 must be used
Spray line cleaning	Needle inside the nozzle to clean the mesh automatically
Safety device	Self-diagnostic functions (e.g. temperature aberration); Sample feed reversal
Air spray pressure gauge	Bourdon tube: 600k Pa (6 kg/cm²)
External dimensions (W x D x H)	1750 x 1060 x 880 mm or 69 x 42 x 35 in
Weight	180 kg or 397 lbs
Power source	AC 200V - 240V, single-phase 24 A
Included Accessories	
Sample liquid tube	Silicone tube - 2 pcs
Safety Cover	Yes
Static removal brush	1pc
Air hose	1 pc
Exhaust Duct	1 pc
Optional Accessories	
Organic Solvent Recovery Unit	GAS410
Inlet/outlet temperature recorder	212792 - factory installed
Viton/Tiron Feeding Tube	Please inquire
Nozzle	4, 5 (options), 3 standard
Compressed air	28 L/min air volume and 8 kgf/cm² compressed air is required
Type of gas	N ₂ gas (99.99% purity, medical grade) is required when using GAS410

Dimensions (Unit:mm)

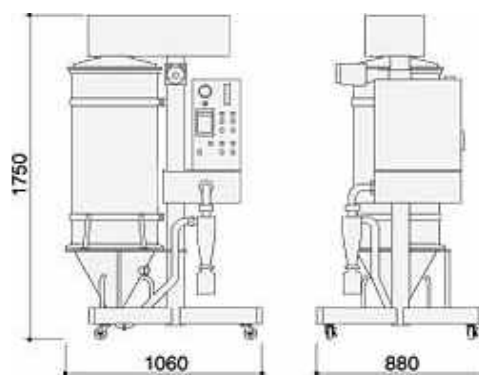

Diagram

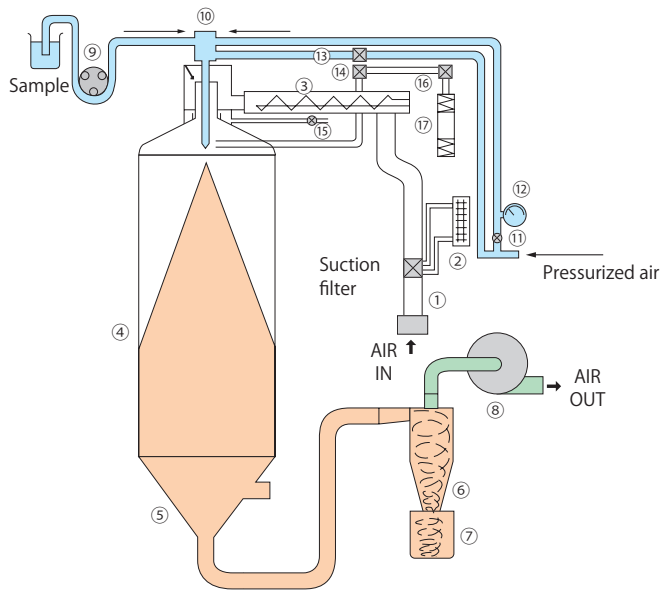

- | | |
|-------------------------------|---------------------------------------|
| (1) Orifice tube | (10) Atomizing nozzle |
| (2) Drying air flow meter | (11) Atomizing pressure control valve |
| (3) Heater | (12) Atomizing pressure gauge |
| (4) Drying chamber | (13) Needle knock Solenoid valve |
| (5) Drying chamber lower half | (14) Nozzle blower Solenoid valve |
| (6) Cyclone | (15) Cool air control valve |
| (7) Product vessel | (16) Head elevation control valve |
| (8) Aspirator | (17) Air cylinder for head elevation |
| (9) Sample feed pump | |

Spraying Nozzle

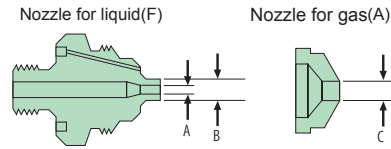

Spraying Nozzle size (µm)

Model	Nozzle No.	Size (µm)	Particle size
3 (Standard)	(F)2850	A 711 B 1270	up to 50µm
	(A)64.5	C 1638	
	4	(F)60100	A 1530 B 2550
(A)120		C 3060	
5		(F)100150	A 2550 B 3825
	(A)130	C 4530	

Particle sizes may vary on samples used and parameter settings.

Control Panel



Multilingual touch screen controller

Application

(1) Spray granulation

With the process of granulation and spheronization, powder liquidity is significantly improved and the pressure is uniform. Applications: aluminum, zirconia, ceramics, heavy metals, cemented carbide fields etc.

(2) Micro capture

In spray drying, the combination of core and coating material is a source solution to obtain encapsulated powder.

Applications:

- Ink for pressure-sensitive paper
- Adjustment of pharmaceutical products flavouring and lyolysis.
- Encapsulation of fragrances used in food and hygiene related products
- Encapsulation of dyes, fertilizers, oils, adhesives etc.

(3) Spray cooling granulation

Difficult to get dry powder, such as wax, oils and fats, fatty acids, etc.

(4) Special applications

Spray concentrated, spray reaction, powder sizing, etc.



0 50 100µm
Powder generated by DL410

Equipment



Static removal brush

Burn prevention safety cover

Burn prevention safety cover and the static removal brush are standard equipment.

Time

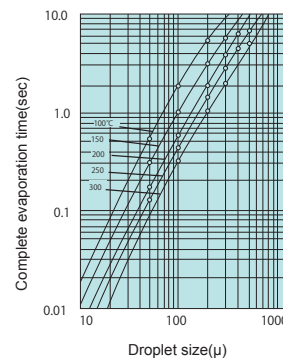

Drying time until the liquid droplets are completely evaporated with hot air.