

OIL VAPOUR DIFFUSION PUMPS

MAXIMISE YOUR PRODUCTIVITY AND PERFORMANCE

HT Diffusion Pumps	316
Vapour Booster Pumps	323
Vapour Pumps for Scientific Instruments and R&D Applications	327

Vapour Pumps

Edwards' vapour pumps suit the widest range of applications, as we offer the most comprehensive range of pumps and accessories available from any supplier. Our industrial, high throughput diffusion pumps and vapour booster pumps fulfil the requirements of applications like vacuum metallurgy, distillation and coating. Our compact scientific pumps are designed for instrument and general R&D applications. By matching the pump of your choice with appropriate accessories, we offer a complete high vacuum pumping solution for all applications.

Pumping Speed and Throughput

The pumping speed (volume flow rate) of a vapour pump is the volume of gas and vapour passing through the inlet of the pump in one second. The unit of measurement is ls^{-1} . The throughput (mass flow rate) is the mass of gas passing through the pump in one second and is measured in mbar ls^{-1} . The throughput of the pump is the same at the pump inlet and pump outlet.

At a given pressure, pumping speed (S) and throughput (Q) are related by the simple equation: $Q = P \times S$, where P is the pressure. You can use this equation to convert between pumping speed and throughput measurements. Below about 1×10^{-3} mbar, pumping speed is the most convenient measure of the pump's performance. At these pressures, the pumping speed is proportional to the diameter of the pump inlet: a large pump is required to obtain higher pumping speeds. Above about 1×10^{-3} mbar, the pump's throughput is most often used to characterise its performance. At these pressures, the performance of the pump is affected by its internal construction as well as its overall size. To choose the best type of vapour pump for your application, you must define the operation pressure and the pumping speed (or throughput) requirement of your application and match these to the performance characteristics of our range of vapour pumps. Remember that, when you calculate the required pumping speed, you must include provision for the process gas throughput, the outgassing of the vacuum system and the leakage into the system. You may also have to consider how quickly you want to achieve the operation pressure.

Measurement Methods

The methods used to measure pressure and flow have become more accurate in recent years allowing much tighter controls over system conditions. The speeds and throughputs quoted in the catalogue for the HT diffusion pumps are based on actual pump data derived

from measurements made with the latest technology total pressure gauges and mass flow transducers in accordance with ISO standards.

Some confusion could arise with previously published speed and throughput figures for older designed pumps where, historically, pressure measurements were made with partial pressure gauges like the McLeod gauge. This older gauge can indicate speeds up to 30% higher than that expected using state of the art total pressure gauges. Further confusion could arise from the measurement standards chosen to determine pumping performance. In the case of AVS (American Vacuum Society), this can indicate speeds and throughput up to 15% higher than ISO figures.

Historical industry practice meant that in considering the above, and potential gauge accuracy of $\pm 15\%$, it was possible to have speeds quoted 60% higher than might be expected using modern total pressure measurement equipment. This should be carefully considered when comparing specifications for older derived data published for similarly sized competitor pumps and the Edwards HT diffusion pumps.

Ultimate Vacuum

The ultimate vacuum of a vapour pump is the lowest pressure achieved in tests on the pump, measured above the inlet of the pump (or above the high vacuum valve for the Diffstaks). The ultimate vacuum depends on: the type of fluid used in the pump; the temperature of the inlet baffle; the amount of outgassing from the vacuum system; and the amount of leakage into the system.

Critical Backing Pressure

The critical backing pressure is the highest pressure that a pump can tolerate in the backing line. If the pressure is higher than the critical backing pressure, the pump may stall. The critical backing pressure depends on: the pump design; the power of the heaters; and the fluid used in the vapour pump.

Backstreaming

Backstreaming is the direct movement of molecules of pump fluid vapour from the pump toward the vacuum system. All Edwards pumps are specially designed to minimise backstreaming; the pumps have a guard ring (sometimes called a cool-cap) fitted above the top jet. The guard ring condenses vapour molecules moving from the top jet toward the vacuum system. In some sensitive applications, backstreaming may be very undesirable; you can minimise backstreaming if you fit a baffle or a trap to the top of the pump.

Vapour Pumps for Industrial Applications

Edwards has long been a pioneer of vapour pumps and diffusion pump technology with innovations such as the diffusion pump cold cap and the combined diffusion pump, the Diffstak. Edwards's range of high throughput diffusion pumps have many advantages in industrial applications. High throughput gives high pumping speeds at high pressures, earlier cross over from backing pump set to the diffusion pump, thus reducing pump down time to process pressure. A high tolerance to gas surges and high critical backing pressures are additional benefits of this range of pumps. The pumps, in back to back testing, are comparable to the best leading competition but also incorporating the above benefits. To offer even higher pumping speeds, of up to $45000 \text{ m}^3\text{h}^{-1}$ at pressures intermediate between mechanical boosters and diffusion pumps Edwards can supply our industrially proven vapour booster pumps. Vapour boosters from Edwards have been proven in the field for over 30 years. A constant program of updates and improvements, with input from OEM's and end users, ensures that the vapour boosters always meet the requirements of the industry. This combined with inherent reliability, ease of use, ease of maintenance and tolerance to a wide range of inlet and exhaust pressures means they have been used extensively in metallurgy and coating industries as well as many other specialist applications.

- Vacuum metallurgy
- Distillation, drying and degassing
- Thin film coating and metallising
- Large scale research

Industrial applications require a robustly designed and constructed vapour pump often with very high throughputs. Edwards provides a complete range of vapour diffusion pumps and vapour boosters to meet these needs. All industrial diffusion pumps are water-cooled.

HT Series Pumps

These pumps are designed to give high throughput (pressure multiplied by pumping speed) at 4×10^{-3} mbar making them ideal for industrial processes that evolve large quantities of gases. Their high critical backing pressure means that they are more tolerant to sudden increases in load. They are particularly suitable for large coating systems and furnaces. All Edwards vapour diffusion pumps are fully fractionating. This means that volatile components are fed to the lower stages of the vapour pump and the vapour fed to the inlet stage is stripped of these fractions and this improves the ultimate vacuum performance of the pump. Conduction cooled baffles above the pump help to prevent pump fluid migration into the vacuum system, which would prevent the pump achieving its ultimate vacuum. Baffles also ensure that backstreaming is minimised. The outgassing from the system, its leak tightness, the vapour pressure of the pump fluid and the number of joints and elastomers used for seals all contribute to the pump down time and ultimate vacuum achievable. Ultimate vacuum is a function of the vapour pressure of the pump fluid selected, at a particular temperature, and in most industrial applications the pump's throughput at a particular pressure is more important than obtaining a very high ultimate vacuum. For these reasons we have elected not to quote an ultimate vacuum for our industrial vapour diffusion pumps, since it would not provide a useful measure of their performance.

By combining Edwards vapour diffusion pumps with either our GV series dry pump combinations or our oil-sealed rotary pump combinations fast pump-down and process times are achievable. Our applications specialists are able to recommend suitable pump combinations to meet specific process requirements.

Vapour Booster Pumps

Vapour booster pumps operate in a similar way to vapour diffusion pumps but generate boiler pressures approximately ten times higher than is typical for a vapour diffusion pump. The high boiler pressure feed supplies powerful ejector nozzles, that are specifically designed to increase further the throughput of the pump. The ultimate pressure of these pumps is typically in the range 10^{-4} to 10^{-5} mbar, above which the pumps exhibit considerable pumping speed for permanent gases. Additionally, they are tolerant to high backing pressures. Vapour boosters are typically used in the 10^{-1} to 10^{-4} mbar range where primary pump combinations are often at their limit and ordinary diffusion pumps exhibit instability.

Edwards booster pumps are particularly tolerant to pumping contaminated systems and processes with high gas loads of hydrogen, hence their suitability for use in metallurgical and chemical process applications. By combining Edwards vapour booster pumps with either our GV series dry pump combinations or our oil-sealed rotary pump combinations fast pump-down and process times are achievable. Our applications specialists are able to recommend suitable pump combinations to meet specific process requirements.

HT DIFFUSION PUMP

MAXIMISE YOUR PRODUCTIVITY AND PERFORMANCE

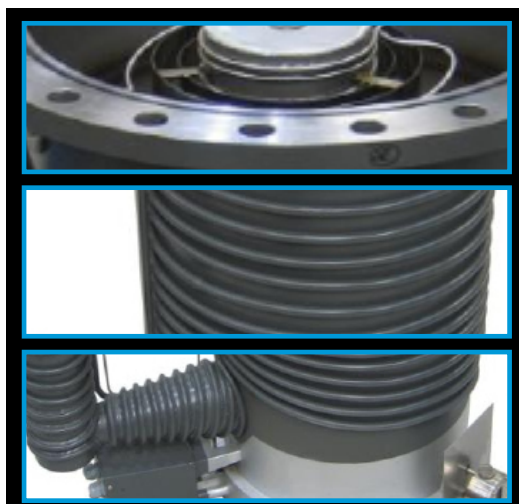

The HT high throughput series is the pinnacle of our diffusion pump knowledge with technology aimed specifically at industrial users. Edwards diffusion pump is designed for all light and heavy duty industrial applications. The robust construction gives high pumping speed at high pressure. The cast and machined aluminium interior provides consistent performance, while the stainless steel body prevents corrosion and ensures process cleanliness. These pumps are designed to give a high throughput (pressure multiplied by pumping speed) at 4×10^{-3} mbar making them ideal for industrial processes that involve large quantities of gases.



Features and Benefits

- Highest throughput of comparative sized pumps.
- Earliest crossover pressure of similar sized pumps.
- Excellent maximum backing line pressure and tolerance to gas surges.
- Comparative pumping speed to similar sized pumps.
- Integral cold cap for best performance and low back streaming.
- Self fractionating for low ultimate pressures.
- Easy change heater assembly.

Applications

- Vacuum metallurgy.
- Distillation, drying and degassing.
- Thin film coating and metalising.
- Large-scale research.

Pump Range

HT

- HT10
- HT16B
- HT20B

Performance Curves

HT10 Diffusion Pump

HT10



Comparative pumping speed

4650 ls^{-1}

AVS pumping speed

Nitrogen 2900 ls^{-1}

Helium 4900 ls^{-1}

Ordering information

Product description	Order no:
HT10 ANSI10/ANSI2, 200 V	B31101200
HT10 ANSI10/ANSI2, 220 V	B31101220
HT10 ANSI10/ANSI2, 380 V	B31101380
HT10 ANSI10/ANSI2, 400 V	B31101400
HT10 ANSI10/ANSI2, 415 V	B31101415
HT10 ANSI10/ANSI2, 460 V	B31101460
HT10 ANSI10/ANSI2, 480 V	B31101480
HT10 EO12/EHVI130, 200 V	B31102200
HT10 EO12/EHVI130, 220 V	B31102220
HT10 EO12/EHVI130, 380 V	B31102380
HT10 EO12/EHVI130, 400 V	B31102400
HT10 EO12/EHVI130, 415 V	B31102415
HT10 ISO320/ISO63, 200 V	B31103200
HT10 ISO320/ISO63, 220 V	B31103220
HT10 ISO320/ISO63, 380 V	B31103380
HT10 ISO320/ISO63, 400 V	B31103400
HT10 ISO320/ISO63, 415 V	B31103415
HT10 ISO320/ISO63, 480 V	B31103480

HT10 Performance Curve

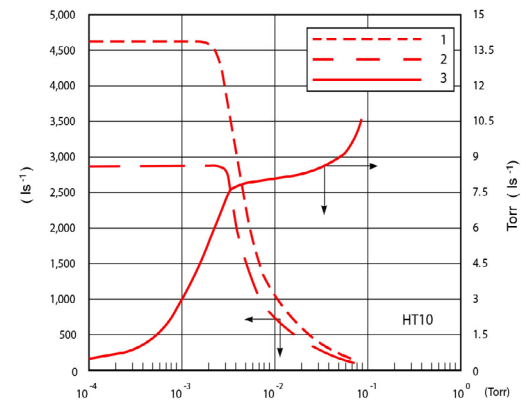
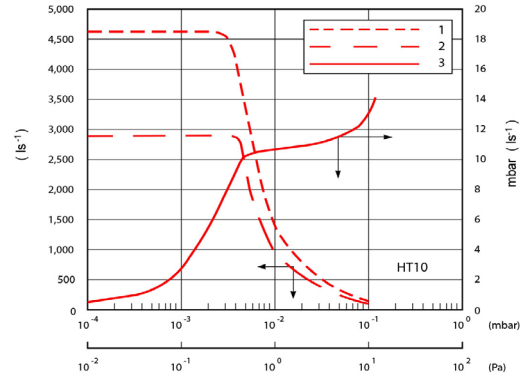

- 1 Comparative pumping speed from back to back testing
- 2 AVS pumping speed
- 3 Throughput curves



HT16B Performance Curve

HT16B

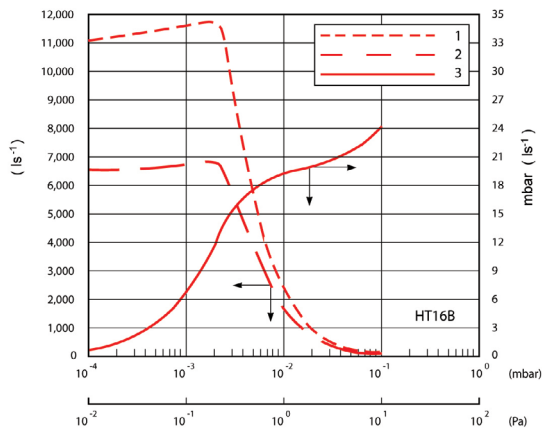
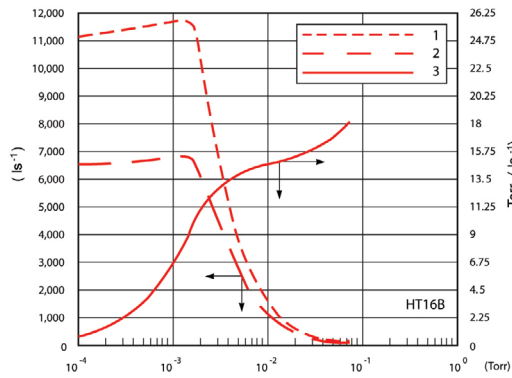

Comparative pumping speed

11580 ls⁻¹

AVS pumping speed

Nitrogen 6700 ls⁻¹

Helium 8500 ls⁻¹



Ordering information

Product description	Order no:
HT16B ANSI16/ANSI3, 200 V	B31220200
HT16B ANSI16/ANSI3, 220 V	B31220220
HT16B ANSI16/ANSI3, 380 V	B31220380
HT16B ANSI16/ANSI3, 400 V	B31220400
HT16B ANSI16/ANSI3, 400 V	B31220415
HT16B ANSI16/ANSI3, 440 V	B31220440
HT16B ANSI16/ANSI3, 460 V	B31220460
HT16B ANSI16/ANSI3, 480 V	B31220480
HT16B ISO500/ISO100, 200 V	B31222200
HT16B ISO500/ISO100, 220 V	B31222220
HT16B ISO500/ISO100, 380 V	B31222380
HT16B ISO500/ISO100, 400 V	B31222400
HT16B ISO500/ISO100, 415 V	B31222415
HT16B ISO500/ISO100, 440 V	B31222440
HT16B ISO500/ISO100, 460 V	B31222460
HT16B ISO500/ISO100, 480 V	B31222480

- 1 Comparative pumping speed from back to back testing
- 2 AVS pumping speed
- 3 Throughput curves

Performance Curves

HT20B Diffusion Pump

HT20B



Comparative pumping speed	
	18000 ls ⁻¹
AVS pumping speed	
Nitrogen	8000 ls ⁻¹
Helium	16000 ls ⁻¹

Ordering information

Product description	Order no:
HT20B ANSI20/ANSI4, 200 V	B31420200
HT20B ANSI20/ANSI4, 220 V	B31420220
HT20B ANSI20/ANSI4, 380 V	B31420380
HT20B ANSI20/ANSI4, 400 V	B31420400
HT20B ANSI20/ANSI4, 415 V	B31420415
HT20B ANSI20/ANSI4, 440 V	B31420440
HT20B ANSI20/ANSI4, 460 V	B31420460
HT20B ANSI20/ANSI4, 480 V	B31420480
HT20B ISO630/ISO160, 200 V	B31422200
HT20B ISO630/ISO160, 220 V	B31422220
HT20B ISO630/ISO160, 380 V	B31422380
HT20B ISO630/ISO160, 400 V	B31422400
HT20B ISO630/ISO160, 415 V	B31422415
HT20B ISO630/ISO160, 440 V	B31422440
HT20B ISO630/ISO160, 460 V	B31422460
HT20B ISO630/ISO160, 480 V	B31422480

HT20B Performance Curve

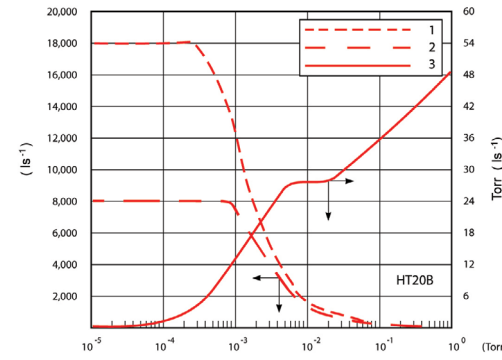
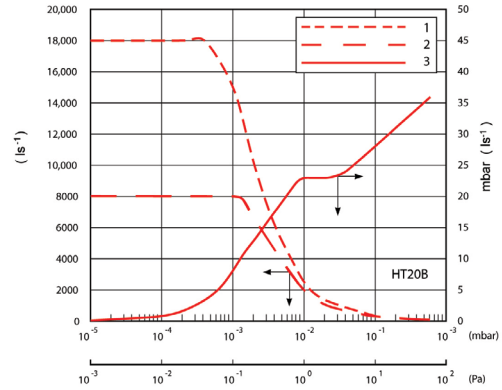

- 1 Comparative pumping speed from back to back testing
- 2 AVS pumping speed
- 3 Throughput curves



Dimensions

HT10 Dimensions

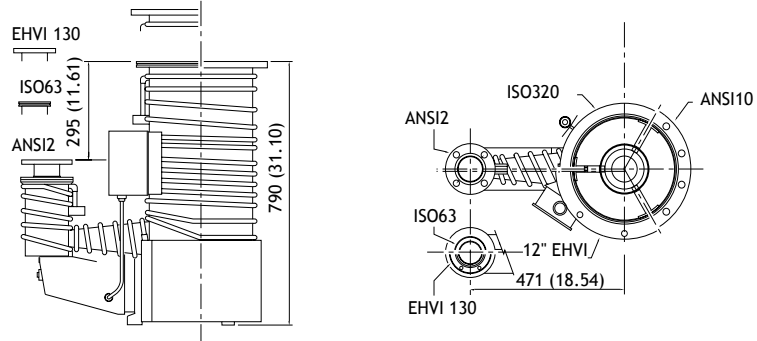

HT16B Dimensions

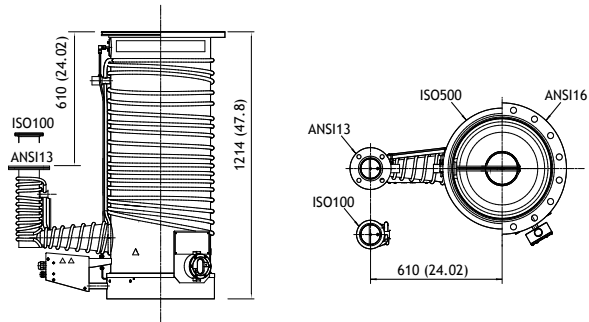

HT20B Dimensions

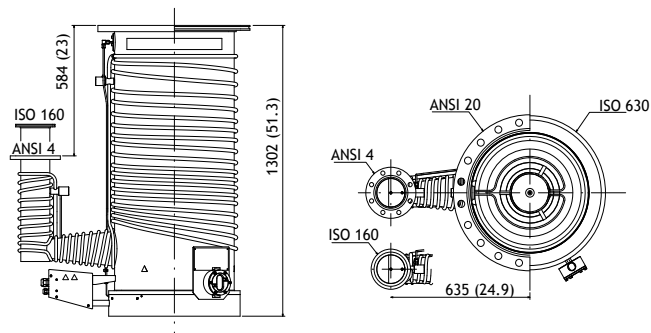

Technical data



	Units	HT10	HT16B	HT20B
Comparative pumping speed				
Nitrogen	ls ⁻¹	4650	11580	18000
ISO Pumping Speed at 10 ⁻³ mbar				
Nitrogen	ls ⁻¹	2900	6700	8000
Helium	ls ⁻¹	4900	8500	16000
AVS pumping				
Nitrogen	ls ⁻¹	2900	6700	8000
Helium	ls ⁻¹	4900	8500	16000
Maximum throughput (Nitrogen)	mbar ls ⁻¹ / Torr ls ⁻¹	10/7.5	18/13.5	24/18
Critical backing pressure (with Edwards 704)	mbar/Torr	1.1/0.8	1.4/1	1.3/1
Minimum backing pump displacement for maximum throughput	m ³ h ⁻¹ /ft ³ min ⁻¹	60/35	94/55	135/80
Recommended backing pump‡		GV80, E2M80	GV80, GXS250, E2M175	GXS250, E2M175
Recommended fluid		Edwards 704	Edwards 704	Edwards 704
Fluid charge (dry)	ml/qt	1250/1.3	2400/2.5	3600/ 3.8
Inlet/backing connection		ANSI10/ANSI12 or EO12 inch/ EO130 mm or ISO320/ISO63	ANSI16/ANSI3 or ISO500/ISO100	ANSI20/ANSI4 or ISO630/ISO160
Water connection	inch NPT female		¾ inch NPT female	
Heater power	kW/hp	5.1/6.8	9/12	12.6/16.9
Warm up time	min	30	60	60
Minimum cooling water flow at 25 °C	l h ⁻¹	400	700	960
	US gal min ⁻¹	1.8	3.1	4.2
Pressure drop across cooling water supply	bar/psi		1/14.5	1.2/17.4
Weight	kg/lbs	80/176	185/408	275/605

‡ These are given for guidance, please contact Edwards for a recommendation of pump combinations best suited to your application.



Service, Spares and Accessories

HT Heaters

Product description	Order no:
HT10 heater 1700 W, 50/60 Hz, 3-ph (three required)	
200 V	H01706010
220 V	H01706011
380 V	H01706012
400 V	H01706013
415 V	H01706014
460 V	H01706015
480 V	H01706016
HT16B heater, 1500 W, 50/60 Hz, 3-phase (six required)	
200 V	H01706020
220 V	H01706021
380 V	H01706022
400 V	H01706023
415 V	H01706024
440 V	H01706028
460 V	H01706025
480 V	H01706026
HT20B heater, 1400 W, 50/60 Hz, 3-phase (nine required)	
200 V	H01706113
220 V	H01706114
380 V	H01706115
400 V	H01706116
415 V	H01706117
440 V	H01706118
460 V	H01706119
480 V	H01706120

VAPOUR BOOSTER PUMP

MAXIMISE YOUR PRODUCTIVITY AND PERFORMANCE

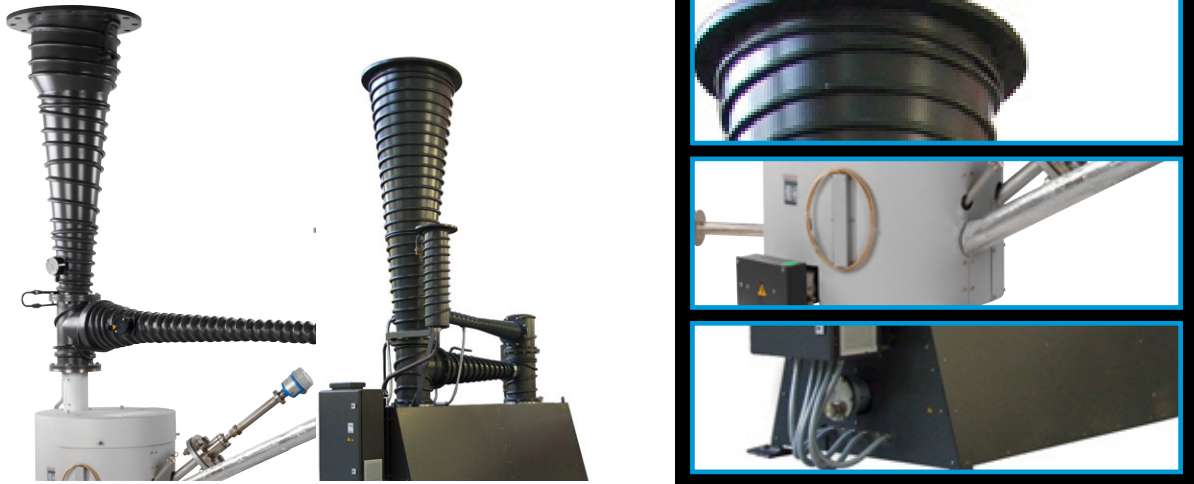

The Edwards vapour booster pumps offer higher pumping speeds, of up to 15000 l s⁻¹ at pressures intermediate between mechanical boosters and diffusion pumps. Vapour boosters from Edwards have been proven in the field for over 30 years. With a constant program of updates and modernisation, with input from OEM's and end users, combined with inherent reliability, ease of use and tolerance to various inlet and exhaust pressures they have been used extensively in metallurgy and coating industries as well as other specialist applications.



Features and Benefits

- Very large pumping speed at high operating pressures.
- Very high throughput at operating pressures.
- Quick crossover for excellent pump-down times.
- Industry proven for over 40 years.
- Excellent reliability.

Applications

- Vacuum metallurgy.
- Distillation, drying and degassing.
- Thin film coating and metalizing.
- Large-scale research.

Pump Range

Vapour Booster Pumps

- 18B4B
- 30B5M



Performance Curves

18B4B Vapour Diffusion Pump

18B4B



AVS pumping speed	
Nitrogen	4000 ls ⁻¹
Helium	6000 ls ⁻¹

18B4B Performance Curve

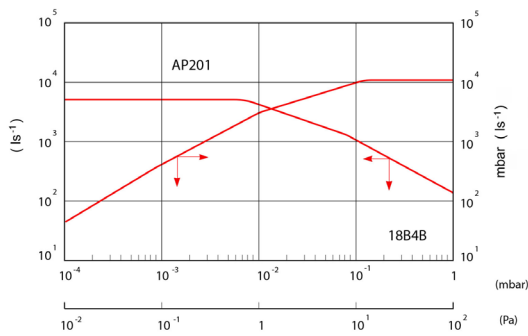

Ordering information

18B4B	Flanges
	1 Edwards (same as previous models 18B4A)
	2 ANSI
	3 ISO

	Oil monitoring
	0 None
	1 Temperature only
	2 Level only
	3 Both temperature and level

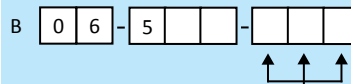

Voltage	
200-210 Volts	200
220-230 Volts	220
240-250 Volts	240
380-440 Volts	380
415-440 Volts	440
460-480 Volts	480

30B5M Vapour Diffusion Pump

30B5M



AVS Pumping Speed	
Air	12500 ls ⁻¹
Hydrogen	15000 ls ⁻¹

Ordering information

Product description	Order no:
30B5M, 200 V, 3Ø, 50/60 Hz with terminal box	B06407200
30B5M, 380 V, 3Ø, 50/60 Hz with terminal box	B06407380
30B5M, 400 V, 3Ø, 50/60 Hz with terminal box	B06407400
30B5M, 415 V, 3Ø, 50/60 Hz with terminal box	B06407415
30B5M, 440 V, 3Ø, 50/60 Hz with terminal box	B06407440
30B5M, 460 V, 3Ø, 50/60 Hz with terminal box	B06407460
30B5M, 480 V, 3Ø, 50/60 Hz with terminal box	B06407480

30B5M Performance Curve

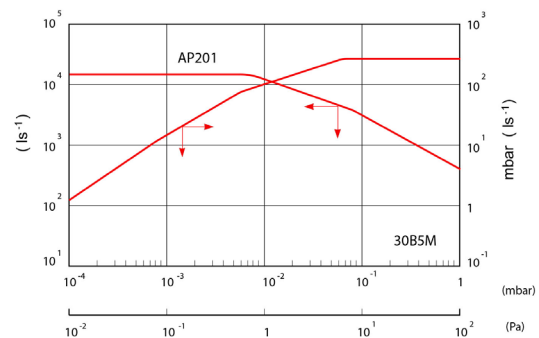

Dimensions

18B4B Dimensions

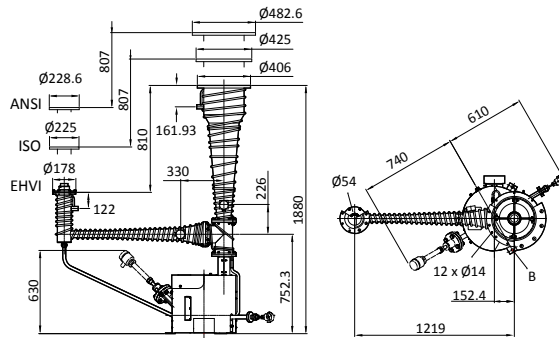

30B5M Dimensions

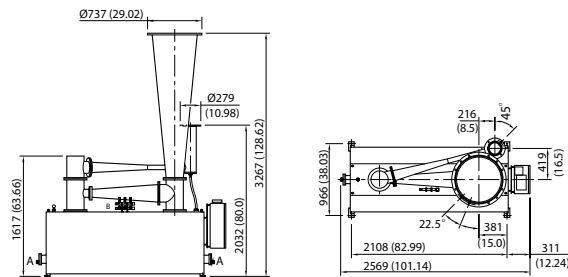

- A Dia. 100 mm boiler cleaning point
- B Position base securing holes $3 \times \frac{7}{16}$ inch (12.7 mm) diameter on $21 \frac{3}{8}$ inch (549mm) p.c.d.



Technical Data



	Units	18B4B	30B5M
AVS Pumping Speed			
air	ls ⁻¹	4000	12500
hydrogen	ls ⁻¹	6000	15000
Maximum throughput	mbar ls ⁻¹ /Torr ls ⁻¹	100/75	300/225
Critical backing pressure (with AP201 fluid)	mbar/Torr	2-2.6/1.5-2	5.3-6/4-4.5
Recommended backing pump displacement	m ³ h ⁻¹ /ft ³ min ⁻¹	190/112	290/171
Recommended backing pump		GXS450, E2M275	GXS450, E2M275
Recommended fluid		Apiezon® AP201	Apiezon® AP201
Fluid charge	litre/qt	10/9.5	55/52
Inlet connection		8x11mm holes on 387.4 PCD (Edwards)/ANSI 12 inch/ISO320	12 x 20.60 holes on 686.0 PCD
Backing connection		2 inch union (Edwards)/ANSI 4 inch/ISO160	4 x 16.70 holes on 235.0 PCD
Water connection	inch BSP	-	1
Heater power	kW/hp	6.0/8	22.5/30
Warming up time for full performance at			
Maximum heater input	min		60
Minimum water flow inlet		375 l h ⁻¹ @ 25 °C/ 1.65 US gal min ⁻¹ @ 25 °C	1950 l h ⁻¹ @ 25 °C/ 8.5 US gal min ⁻¹ @ 25 °C
Water block threaded hole	inch BSP	½	-
Weight	kg/lbs	165/365	620/1367

VAPOUR PUMPS FOR SCIENTIFIC INSTRUMENTS AND R&D APPLICATIONS

MAXIMISE YOUR PRODUCTIVITY AND PERFORMANCE



Scientific and R&D applications require special vapour pumps and accessories. It is important to minimise any backstreaming of the vapour pump fluid, and the number of elastomer seals used in system design needs to be kept to a minimum, to give clean pumping with minimal outgassing. For bench-top or transportable instruments, compact air-cooled pumps are essential.

Edwards offers a range of vapour pumps and accessories which are designed to meet these needs.



Diffstak Vapour Diffusion Pumps

The compact water-cooled Diffstak pumps with an integral cooled baffle offer exceptionally clean pumping with very low backstreaming, reduced outgassing, and a reduction in the number of elastomer seals required for installation.

The Diffstak design has been proven over many years with thousands of pumps installed. They are supplied in two types: standard, and unvalved (C-collar model pumps).

The Edwards Diffstak 63 (ISO 63 inlet), 100 (ISO100 inlet), 160 (ISO160 inlet), 250 (ISO250 inlet), design has been proven over many years with thousands of pumps installed.

The standard Diffstak pumps have integral high vacuum valves and water-cooled baffles, which are supplied as either manually operated (M-model pumps) or pneumatically operated (P-model pumps).

When comparing pumping speeds, note that the speeds quoted for valved Diffstaks are the speeds above the high vacuum valve, taking full account of the valve's impedance.

The unvalved Diffstaks are for systems requiring the highest possible ultimate vacuum or for those which do not need a high vacuum valve.

All sizes are available with ISO flanges while two sizes are also available with CF flanges (F-ConFlat® model pump).

The complete range is shown in the table below. Refer to the following pages for full technical data for each of the pumps and also for full details of installations, spares and accessories.

Standard Diffstak	Unvalved Diffstak	
	ISO Flange	CF Flange
63/150M or P	63/150C	–
100/300M or P	100/300C	100/300F
160/700M or P	160/700C	160/700F
250/2000M or P	250/2000C	–



Technical Data

The following table shows the critical backing and ultimate pressures for the diffusion pump range:

Fluid	Critical Backing Pressure (mbar)	Ultimate Pressure (mbar)
Santovac® 5	0.6	5×10^{-9}
Silicone DC702	1.2	7×10^{-6}
Silicone Edwards 704	0.8	7×10^{-8}
Silicone DC705	0.6	3×10^{-8}

Data summary vapour pumps

Pump	63/150M 63/150P	63/150C
Pumping speed (M&P/C)		
Nitrogen	ls ⁻¹	135
Hydrogen	ls ⁻¹	200
Minimum backing pump displacement*	m ³ h ⁻¹	5
Inlet connection	ISO63	ISO63
Backing connection	NW10	NW10
Oil charge capacity	60 ml	60 ml
Heater power	450 W	450 W
Weight (M&P/C)	9 kg/5 kg	9 kg/5 kg

Pump	100/300M 100/300P	100/300C 100/300F
Pumping speed (M&P/C)		
Nitrogen	ls ⁻¹	280
Hydrogen	ls ⁻¹	500
Minimum backing pump displacement*	m ³ h ⁻¹	5
Inlet connection	ISO100	ISO63
Backing connection	NW25	NW10
Oil charge capacity	125 ml	60 ml
Heater power	650 W	450 W
Weight (M&P/C)	12/13 kg 9/10 kg	12/13 kg 9/10 kg

Pump	160/700M 160/700P	160/700C 160/700F
Pumping speed (M&P/C)		
Nitrogen	ls ⁻¹	700
Hydrogen	ls ⁻¹	1300
Minimum backing pump displacement*	m ³ h ⁻¹	12
Inlet connection	ISO160	ISO160/8 inch
Backing connection	NW25	NW25
Oil charge capacity	250 ml	250 ml
Heater power	1350 W	1350 W
Weight (M&P/C)	26/27 kg 18/20 kg	26/27 kg 18/20 kg

Pump	250/2000M 250/2000P	250/2000C
Pumping speed (M&P/C)		
Nitrogen	ls ⁻¹	2000
Hydrogen	ls ⁻¹	3000
Minimum backing pump displacement*	m ³ h ⁻¹	40
Inlet connection	ISO250	ISO250
Backing connection	NW40	NW40
Oil charge capacity	500 ml	500 ml
Heater power	2250 W	2250 W
Weight (M&P/C)	59/60 kg 46 kg	59/60 kg 46 kg

Ordering information

Product description	Order no:	Product description	Order no:
Standard Diffstak 63/150M		Standard Diffstak 160/700M	
110-125 V 1-ph 50/60 Hz	B34431976	110-125 V 1-ph 50/60 Hz	B34831976
210-225 V 1-ph 50/60 Hz	B34431977	210-225 V 1-ph 50/60 Hz	B34831977
230-250 V 1-ph 50/60 Hz	B34431978	230-250 V 1-ph 50/60 Hz	B34831978
Standard Diffstak 63/150P		Standard Diffstak 160/700P	
110-125 V 1-ph 50/60 Hz	B34432976	110-125 V 1-ph 50/60 Hz	B34832976
210-225 V 1-ph 50/60 Hz	B34432977	210-225 V 1-ph 50/60 Hz	B34832977
230-250 V 1-ph 50/60 Hz	B34432978	230-250 V 1-ph 50/60 Hz	B34832978
Unvalved Diffstak 63/150C		Unvalved Diffstak 160/700C	
110-125 V 1-ph 50/60 Hz	B34433976	110-125 V 1-ph 50/60 Hz	B34833976
210-225 V 1-ph 50/60 Hz	B34433977	210-225 V 1-ph 50/60 Hz	B34833977
230-250 V 1-ph 50/60 Hz	B34433978	230-250 V 1-ph 50/60 Hz	B34833978
Supplied with: NW10 elbow, NW10 centring-ring, NW10 clamp, water pipe couplings and ferrules, inlet ISO 63 Co-Seal.		Unvalved Diffstak 160/700F	
Standard Diffstak 100/300M		110-125 V 1-ph 50/60 Hz	B34840976
110-125 V 1-ph 50/60 Hz	B34631976	210-225 V 1-ph 50/60 Hz	B34840977
210-225 V 1-ph 50/60 Hz	B34631977	230-250 V 1-ph 50/60 Hz	B34840978
230-250 V 1-ph 50/60 Hz	B34631978	Supplied with: NW25 elbow, NW25 centring-ring, NW25 clamp, water pipe couplings and ferrules, inlet ISO 160 Co-Seal (C version only).	
Standard Diffstak 100/300P		Standard Diffstak 250/2000M	
110-125 V 1-ph 50/60 Hz	B34632976	110-125 V 1-ph 50/60 Hz	B35031976
210-225 V 1-ph 50/60 Hz	B34632977	210-225 V 1-ph 50/60 Hz	B35031977
230-250 V 1-ph 50/60 Hz	B34632978	230-250 V 1-ph 50/60 Hz	B35031978
Unvalved Diffstak 100/300C		Standard Diffstak 250/2000P	
110-125 V 1-ph 50/60 Hz	B34633976	110-125 V 1-ph 50/60 Hz	B35032976
210-225 V 1-ph 50/60 Hz	B34633977	210-225 V 1-ph 50/60 Hz	B35032977
230-250 V 1-ph 50/60 Hz	B34633978	230-250 V 1-ph 50/60 Hz	B35032978
Unvalved Diffstak 100/300F		Unvalved Diffstak 250/2000C	
110-125 V 1-ph 50/60 Hz	B34640976	110-125 V 1-ph 50/60 Hz	B35033976
210-225 V 1-ph 50/60 Hz	B34640977	210-225 V 1-ph 50/60 Hz	B35033977
230-250 V 1-ph 50/60 Hz	B34640978	230-250 V 1-ph 50/60 Hz	B35033978
Supplied with: NW25 elbow, NW25 centring-ring, NW25 clamp, water pipe couplings and ferrules inlet ISO co-seal (C version only).		Supplied with: NW40 elbow, NW40 centring-ring, NW40 clamp, water pipe couplings and ferrules, inlet ISO 250 trapped O-ring.	



Diffstak Installation

- M-model pumps have a manually operated high vacuum valve.
- P-model pumps have a pneumatically operated high vacuum valve.

Both M-model and P-model pumps have inlet flanges which are compatible with ISO flanges: the internal diameter of the inlet flange is narrower and the flange is deeper than a standard ISO flange, to accommodate the high vacuum valve.

- C-model pumps do not have a high vacuum valve and have an ISO flange on the inlet.
- F-model pumps do not have a high vacuum valve and have a CF flange on the inlet.

Refer to the diagrams and the tables on these pages to identify the pipeline components and valves required to complete the typical Diffstak installation shown. Items supplied with the pump are shown as a dotted line. Read the footnotes below the diagrams and the tables for more information and for details of the installation requirements for the different models of Diffstaks.

63/150, 100/300, 160/700 Installation

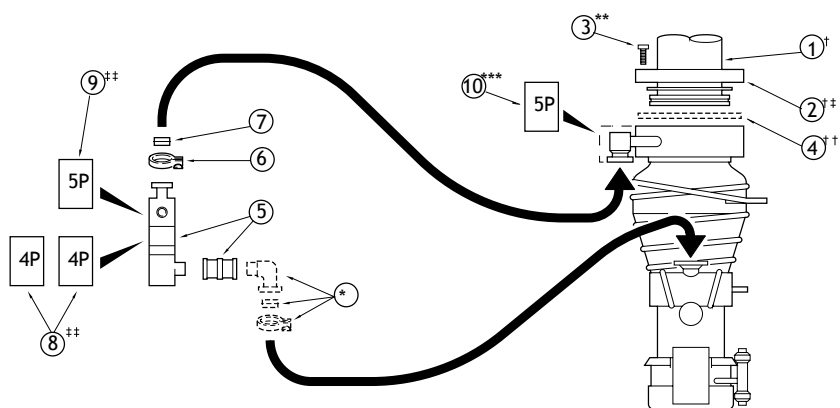

Diagram key	Component description	63/150 component		100/300 component		160/700 component	
		Size	Quantity	Size	Quantity	Size	Quantity
1††	ISO tube/collar assembly	ISO63	1	ISO100	1	ISO160	1
2†	Rotable flange pack	ISO63	1	ISO100	1	ISO160	1
3**	Bolts (size × minimum length, mm)						
	M- and P-model	M8 × 75	4	M8 × 75	8	M10 × 90	8
	F-model	–	–	M8 × 55	16	M8 × 60	20
4††	Inlet seal	ISO63	1	ISO100	1	ISO160	1
5	BRV valve, manual	BRV10M	1	BRV25M	1	BRV25M	1
	BRV valve, pneumatic	BRV10P	1	BRV25P	1	BRV25P	1
6	Clamp	NW10	1	NW25	1	NW25	1
7	O-ring assembly	NW10	1	NW25	1	NW25	1
8‡‡	4-port light-weight electropneumatic control valve	–	2	–	2	–	2
9‡‡	5-port electropneumatic control valve	–	1	–	1	–	1
10***	5-port electropneumatic control valve	–	1	–	1	–	1

* These items are supplied with the pumps, except that the inlet seal for the F-model pumps is not supplied.

† Not required for F-model pumps; use CF fittings (which must be obtained from another supplier)

‡ Not required for C-model pumps; use claw clamps to bolt the pump ISO inlet flange directly to the ISO tube/collar assembly.

** Bolts are not available from Edwards. Bolts are not required for C-model pumps; use claw clamps to bolt the pump ISO inlet flange directly to the ISO tube/collar assembly; use 4 claw clamps for ISO63, ISO100 and ISO160 flanges.

† These inlet seals are suitable for standard, cryo-cooled and C-model pumps only; use CF fittings (which must be obtained from another supplier) for F-model pumps.

‡‡ Required only for pneumatic operation BRV valves; use either 1 5-port control valve or 2 4-port control valves. If you use 2 4-port control valves, you can use the isolation position of the BRV valve.

*** Required only for P-model pumps, to control the operation of the high vacuum valve.

250/2000 Installation

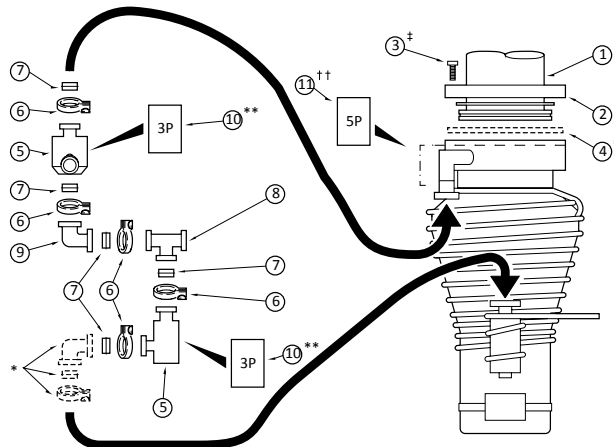

Diagram key	Component Description	Component	
		Size	Quantity
1	ISO tube/collar assembly	ISO250	1
2†	Rotable flange pack	ISO250	1
3‡	Bolts (size × minimum length, mm) M- and P-model	M10 × 110	12
4	Inlet seal, trapped O-ring	ISO250	1
5	PV40 valve, manual	PV40MK	2
	PV40 valve, pneumatic	PV40PK	2
6	Clamp	NW40	5
7	O-ring assembly	NW40	5
8	T-piece	NW40	1
9	Elbow	NW40	1
10**	3-port electropneumatic control valve	–	2
10 ††	5-port electropneumatic control valve	–	1

* These items are supplied with the pump.

† Not required for C-model pumps; use 6 claw clamps to bolt the pump ISO inlet flange directly to the ISO tube/collar assembly.

‡ Bolts are not available from Edwards. Bolts are not required for Model-C pumps; use 6 claw clamps to clamp the pump ISO inlet flange directly to the ISO tube/collar assembly.

** Required only for pneumatic operation PVPK valves; use 1 3-port control valve for each of the two PVPK valves.

†† Required only for P-model pumps, to control the high vacuum valve.

Vapour Pump Spares

Product description	Order no:	Product description	Order no:
Diffstak 63 Heater (0.45 kW)		Diffstak 160 heaters (one of each power required)	
110-125 V	H01700182	110-125 V 0.35 kW	H01700102
210-225 V	H01700186	210-225 V 1 kW	H01700059
230-250 V	H01700191	230-250 V 0.35 kW	H01700107
Diffstak 100 Heater (0.65 kW)		210-225 V 1 kW	H01700063
110-125 V	H01700199	230-250 V 0.35 kW	H01700113
210-225 V	H01700097	230-250 V 1 kW	H01700054
230-250 V	H01700190	Diffstak 250 heaters (one of each power required)	
		110-125 V 0.85 kW	H01700140
		110-125 V 1.4 kW	H01700161
		210-225 V 0.85 kW	H01700134
		210-225 V 1.4 kW	H01700155
		230-250 V 0.85 kW	H01700137
		230-250 V 1.4 kW	H01700158

This page has intentionally been left blank