

Series 354 Micro-Ion® Module Gauge Replacement Instructions

For Catalog Numbers 354003-## and 354050-##



Replacing the Gauge

Remove the existing gauge

To remove the existing gauge from the Module, turn OFF power to the gauge and unplug the electrical connector. Remove the Micro-Ion Module from the vacuum system. Remove the four Phillips-head screws from the plate attached to the gauge. Gently pull (unplug) the gauge from the module.

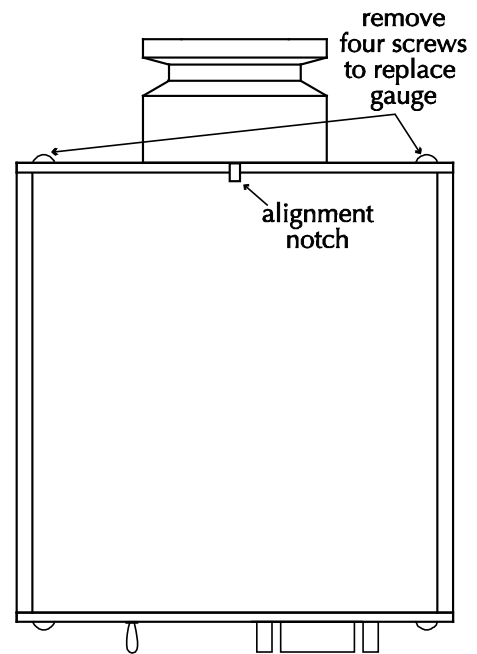

Safety Instructions

Read this instruction sheet before installing, using, or servicing this equipment. If you have any doubts about how to use this equipment safely, contact Granville-Phillips Customer Service at the location listed on the back of this instruction sheet.

Gauge Handling

The Micro-Ion Gauge is double-packaged at the factory for cleanroom compatibility. Handle carefully to avoid damaging the vacuum port screen after the cap plug is removed. To reduce the chance of contamination, do not remove a Micro-Ion Gauge from its inner bag until just before it is to be connected to the vacuum system.

Avoid contaminating the Micro-Ion Gauge. Do not touch the vacuum connection port. Follow good vacuum practice.

To minimize the possibility of leaks, do not scratch the vacuum connection seal surfaces.

Insert the new gauge

Insert the new gauge by aligning the notches on the gauge collar plate and the Module body, and gently insert the gauge pins into the socket on the circuit board. Install and tighten the four Phillips-head screws.



Be aware that an electrical discharge through a gas may couple dangerous high voltage directly to an ungrounded conductor almost as effectively as would a copper wire connection. A person may be seriously injured or even killed by merely touching an exposed ungrounded conductor at high potential. This hazard is not peculiar to this product.



All conductors in, on, or around the vacuum system that are exposed to potential high voltage electrical discharges must be shielded at all times or must be connected to an Earth ground at all times to protect personnel. Verify that the vacuum port to which the Micro-Ion Gauge is mounted is electrically grounded. It is essential for personnel safety as well as proper operation that the envelope of the gauge be connected to a facility ground. Use a ground lug on a flange bolt if necessary.

Do not touch the Micro-Ion Gauge during degas operation \neq burns can occur.

Return policy: The Micro-Ion Gauge cannot be returned to Granville-Phillips for credit if the inner bag seal is broken.

Nominal Operating Parameters

Collector potential.....	0 V
Grid potential.....	+180 V
Filament potential.....	+30 V
Filament heating voltage.....	2.3 V maximum
Filament heating current.....	3 A maximum
Degas grid potential.....	+250 V
Emission current.....	0.01 to 4 mA
Degas emission current.....	15 mA maximum
X ray limit.....	< 3 x 10 ⁻¹⁰ Torr < 4 x 10 ⁻¹⁰ mbar < 4 x 10 ⁻⁸ Pa
N ₂ sensitivity.....	20 Torr ⁻¹ 15 mbar ⁻¹ 0.15 Pa ⁻¹

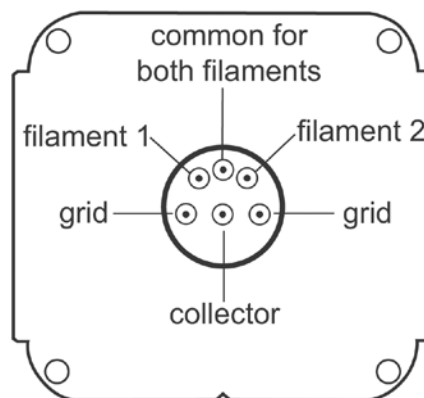

Micro-Ion Gauge Pinout

Catalog Number Matrix

Micro-Ion Module Replacement Gauge	##	354	###	-	##
Tailored Versions	20				
Gauge Options					
Std. Replacement Gauge	003				
Tantalum Clip Version	050				
Filament Options					
Yttria-coated Iridium	Y				
Tungsten	T				
Fitting Options					
NW16KF	D				
NW25KF	E				
NW40KF	K				
1.33 inch (NW16CF)	F				
2.75 inch (NW35CF)	G				
1/2 inch 8VCR-type male	H				
NW16KFL*	M				
NW25KFL*	N				
NW40KFL*	L				

* Extended neck to accommodate baffle p/n 354038 (not included)



MKS Instruments, Inc.
 Granville-Phillips Products Division
 6450 Dry Creek Parkway
 Longmont, CO 80503-9501
 Phone: 1-303-652-4400 or 1-800-776-6543

Addendum
 Part Number 354012
 Revision C
 September 2014
 Page 2 of 2

Visit our website at www.mksinst.com/granville-phillips

©2014, MKS Instruments, Inc. All rights reserved. Granville-Phillips® and Micro-Ion® are registered trademarks of MKS Instruments, Inc.