

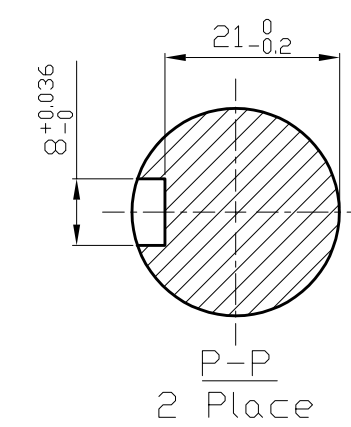

parts	Material	Quantity
o-ring G50	FKM	1

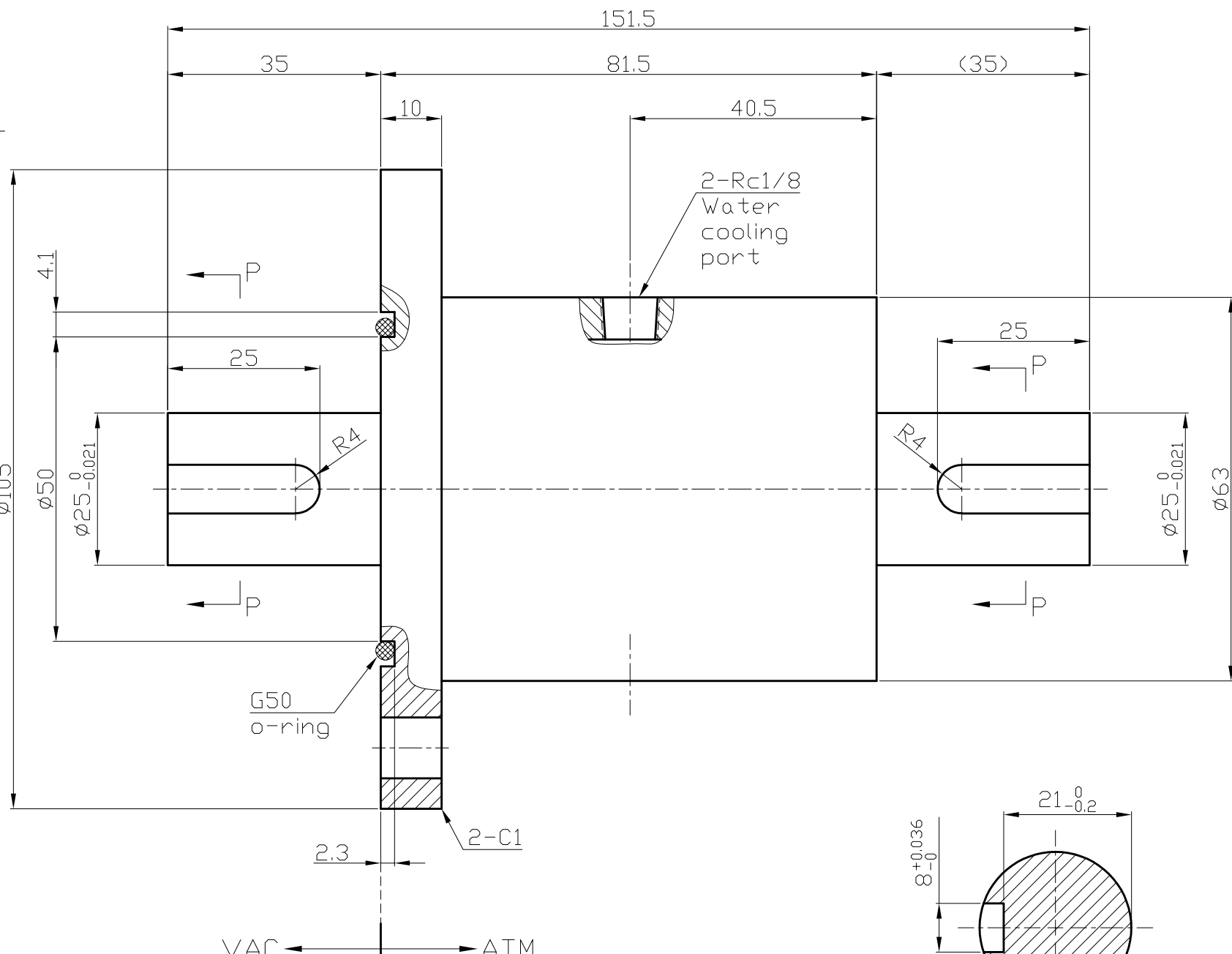
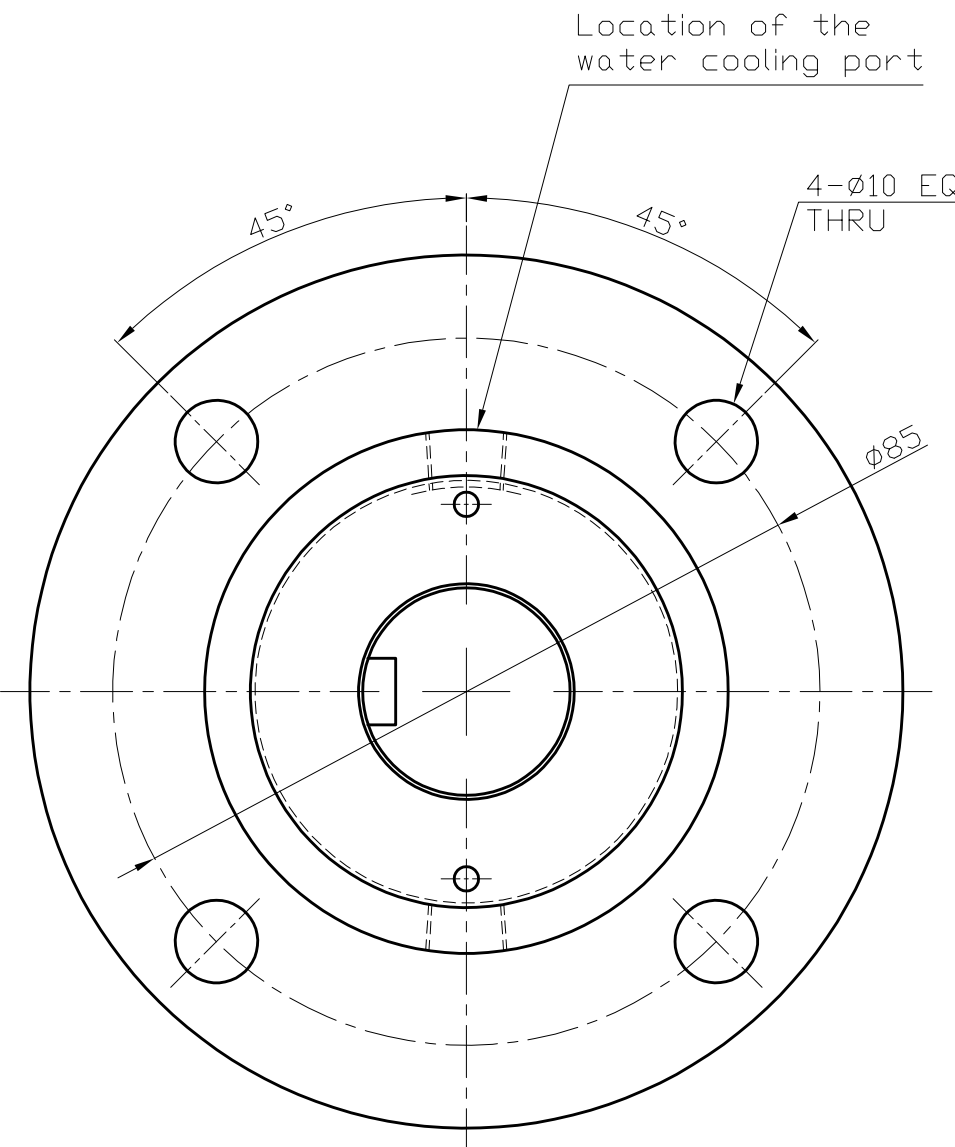

Signature Confirmation	Signature Date:
------------------------	-----------------

- Technical Requirements**
1. Dimensional tolerance and positional tolerance better than ISO 2768.
 2. Allowed Helium Leakage Rate: 1x10E-12 Pa.m3/sec.
 3. Operating Environment:
 - (1) Operating Temperature Range: 0-80°C (for magnetic seal location).
 - (2) Type of Gas: Non-reactive gas.
 - (3) Operating Speed: Below 500 RPM.
 - (4) Attainable Vacuum Level: 1x10E-7 Torr.
 - (5) Maximum Pressure Differential: 0.1 MPa.
 - (6) Dust, Oil, Water: None.

Guarantee and Disclaimer

1. Warranty Period
 - o New products: 1 year from the date of factory shipment.
 - o Repaired products (outside warranty period): 3 months from the date of factory shipment.
2. Warranty Coverage
 - o During the warranty period, the company is responsible for repairing or replacing faults caused by design or manufacturing reasons.
 - o The warranty does not cover losses due to equipment malfunction and shutdown.
3. Exemption Conditions

Even within the warranty period, the following situations are not covered:

 - a. Faults caused by failure to operate, inspect, or maintain according to the user manual.
 - b. Faults caused by repairs or modifications performed by other companies.
 - c. Faults caused by force majeure such as fire, flood, earthquake, etc.
 - d. Faults caused by intrusion of water, dust, etc., into the magnetic fluid.
4. Your company needs to conduct thorough testing on the usability of magnetic fluid in the equipment:
 - a. Before mass production of magnetic fluid products, your company must conduct comprehensive feasibility verification, including but not limited to performance testing, quality control, environmental adaptability testing, safety assessments, and other validation work.
 - b. The company provides support and technical consultation during the design and development of magnetic fluid, but assumes no responsibility for any issues arising from insufficient validation by your company before or after mass production.
 - c. Your company is solely responsible for any losses, damages, or liabilities resulting from insufficient validation. The company does not bear any direct or indirect responsibility.
 - d. Please ensure that all necessary validation work is completed before mass production of magnetic fluid to ensure product quality and safety.

Surface finish	Sealing surface	Assembly surface	Other
1.6	1.6	1.6	3.2

MARKING	NUB	CONTENT	DATE	HOUSING SUS304	WEIGHT	PROPORTION	FEEDTHROUGH
CHECKED		WANG	20240813	SHAFT SUS420		1:1	product name
PREPARED		WANG	20240813	M/N:	***		SFB025WNC23
ENGINEER		GU	20240813	1 of 1	VERSION	A	customer part number:
ACKNOWLEDGE		XIAOLIN	20240813				***