



# HiCube 300 Neo, DN 100 CF-F, MVP 015-2



## HiCube 300 Neo, DN 100 CF-F, MVP 015-2

- Compact series of pumping stations for all high vacuum applications
- Simple operation with touch display
- Remote control via web server available
- Reliable and robust

### Dimensions

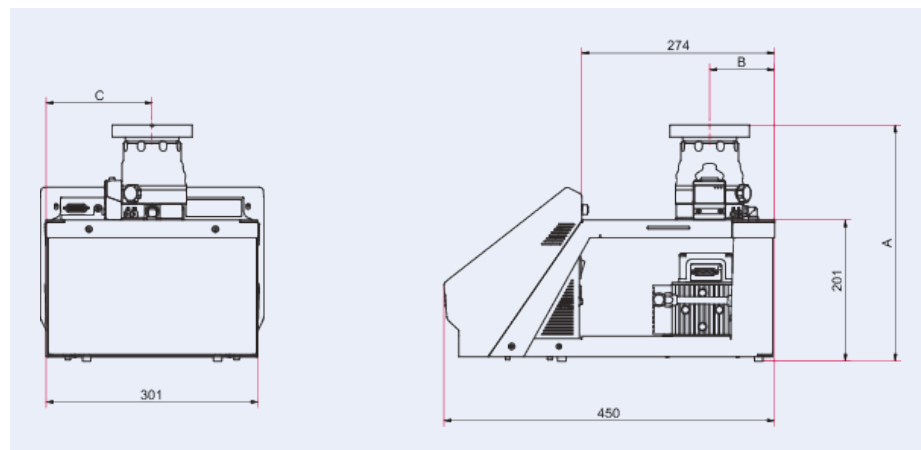

A	408 mm
B	108 mm
C	171 mm

### Technical Data

### HiCube 300 Neo, DN 100 CF-F, MVP 015-2

Cooling method	Air (Forced convection)
Pumping speed backing pump	50 Hz: 1 m <sup>3</sup> /h
Motor for region	Worldwide
Type	Turbo pumping station
Turbopump	HiPace 300
Ambient temperature	5 – 40 °C
Rated power at max. rotation speed	275 W
Input voltage(s)	100 – 120 / 200 – 240 V AC (±10 %), 50/60 Hz
Emission sound pressure level (EN ISO 2151)	≤50 dB(A)
Pumping speed for N <sub>2</sub>	260 l/s
Weight	21 kg   46.3 lb
Backing pump	MVP 015-2
Fore-vacuum safety valve	No
Connection flange (in)	DN 100 CF-F
Connection flange (out)	Silencer, G 1/8"

<b>Order number</b>	HiCube 300 Neo, DN 100 CF-F, MVP 015-2
HiCube 300 Neo, DN 100 CF-F, MVP 015-2	PM Q121 001 00

## Your Success. Our Passion.

We give our best for you every day –  
worldwide!

Are you looking for an optimum vacuum solution?

**Talk to us:**  
Pfeiffer Vacuum GmbH  
**Germany**  
**T +49 6441 802-0**

Or scan the barcode, to visit our web page:



<https://webportal.pfeiffer-vacuum.com/global/en/contact>



Errors and/or changes excepted. - 7/6/2024

Follow Us On Social Media  
#pfeiffervacuum



**PFEIFFER**  **VACUUM**

[www.pfeiffer-vacuum.com](http://www.pfeiffer-vacuum.com)